



TTC-1 Sensing Module

Installation, Operation and Maintenance Instructions

Description

The TTC-1 sensing module is used with TraceTek sensing cables to detect liquid leaks. The module provides visual indication when a leak or cable break has occurred and has relay contacts to connect the TTC-1 to external devices for remote monitoring and control.

Electrical Codes

Installation must be done in accordance with national and local codes and regulations that apply. The TTC-1 must be installed in ordinary areas only.

Module Location

Enclosure rating: IP 20 / NEMA 1

Operating temperature range: 0 to 50°C (32° to 122°F)

Specifications

Maximum sensing cable length: 75 m (250 feet)

- Leader cable length is not included in the length limitation.

Input power:

- 12 to 24 Volts AC – 0.25 A or
- 15 to 24 Volts DC – 0.15 A
- When using a transformer, use UL listed Class II transformer rated at 24 V, 20 VA

Recommended fuse rating: 3 A

Relay ratings: 3 A: 30 Volts DC or 24 Volts AC

Approvals



LISTED
92K4
PROCESS MANAGEMENT EQUIPMENT

TYPE NM



Class 2

Installation Materials and Tools Required

Wall fastener (2 ea for surface mounting only)

Parts and Materials

- 1 ea TTC-1 Sensing Module
- 1 ea TTC-1 Installation, Operation and Maintenance Instructions
- 1 ea TTC-1 Wall Label
- 4 ea Strain Reliefs

Optional Accessories

- TTC-DRC DIN Rail Clip
- TTE-XAL External Loud Alarm

Important Notes

- The TTC-1 system is designed for use with TraceTek sensing cables only. A TTC-1 based system will detect and alarm on all leaks of fluids detected by the TraceTek cable as per the appropriate cable data sheet.
- Transient spills and contamination may also activate the system. Users should consider this operational function when determining the suitability of the TraceTek system for specific applications.
- The system has not been designed for repetitive cycling.
- Always connect the Leak Detection relay to an annunciation device so that an operator is notified and can verify proper operation if automatic equipment is connected.

Maintenance personnel should examine the sensing cable for cleanliness and verify proper operation of this unit at least every six (6) months.

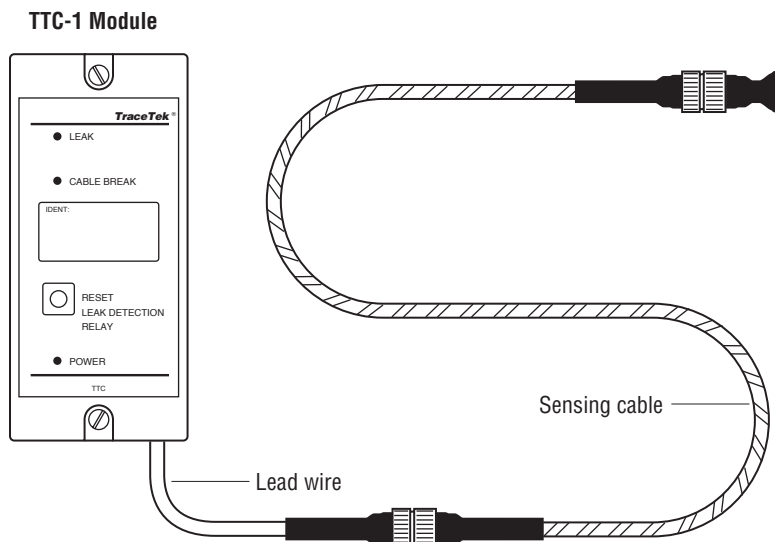

Figure 1: Typical system diagram

TTC-1 Sensing Module Installation, Operation and Maintenance Instructions

Preparation for Mounting

Open the knockouts as required on the base unit. The holes are sized for the PG-9 threaded strain relief provided in the kit.

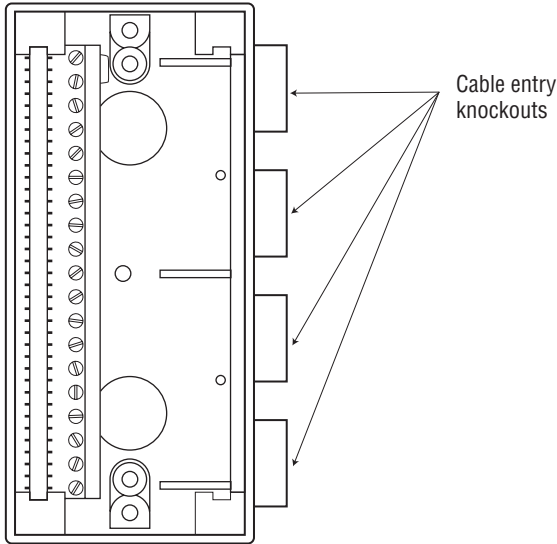

Figure 2: Wall mounting

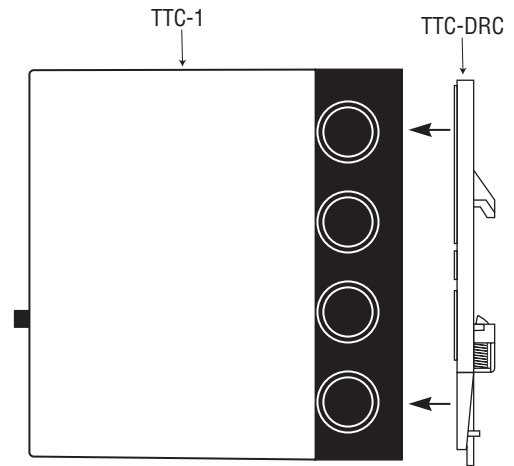

Figure 3: DIN rail mounting

For Wall Mounting

Use the two holes in the back plate to mount the TTC base unit to the wall using suitable wall fasteners. For proper orientation, the terminal strip must be on the left, as shown in Figure 2.

For DIN 1 Rail Mounting

Attach the optional rail mounting clip (TTC-DRC) to the base unit and clip base unit on rail. Follow instructions supplied with the TTC-DRC kit.

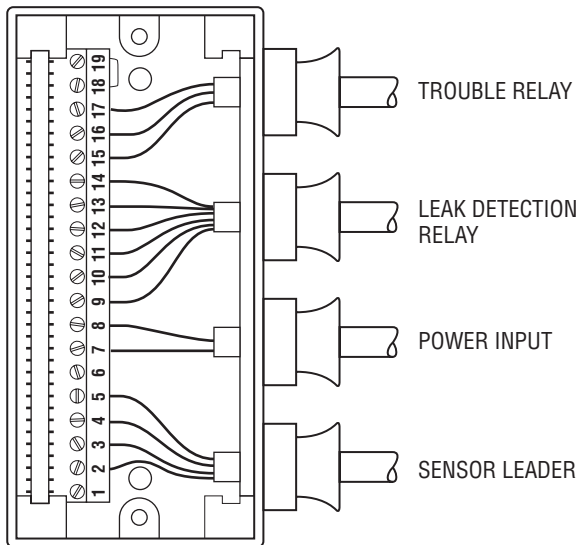

Figure 4: Terminal block wiring

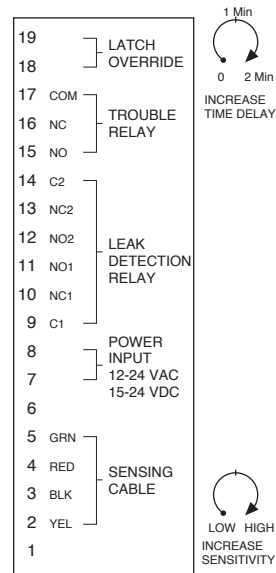

Figure 5: Typical terminal block label
(relay contacts shown in normal operating mode with no alarm condition)

TTC-1 Sensing Module Installation, Operation and Maintenance Instructions



WARNING: To avoid electrical shock - all wiring must be done with the power off.

Use of the Terminals

Strip all wire insulation back 3/8 inch. Push leader cable, power supply and relay contact wires through the strain reliefs as needed. Wires should be connected to the terminal strip following the label on the rear cover plate of the TTC-1. (See Figure 5.)

Power Supply Connection

Do not ground either leg of the power supply. There is no polarity requirement when using a DC power supply. Connection of more than one TTC-1 to a common power supply is not recommended.

Maximum wire size: 14 AWG.

Relay Connections



NOTE: Always connect the alarm relay to an annunciator device so that an operator is notified and can verify proper operation of any connected automatic equipment.

Trouble Relay:

One relay with single pole, double throw contact.

The relay is normally energized. Loss of power at the TTC-1 module causes the relay to switch to the alarm condition.

Leak Detection Relay:

One alarm with double pole, double throw contacts.

Module Field Adjustments:

Time Delay can be increased from immediate to approximately 2 minutes using adjustment screw on rear panel.

Sensitivity can be increased or decreased from factory setting with adjustment screw on rear panel.

Leak detection relay latch can be disabled by removing jumper wire from terminals 18 to 19.

Final Assembly

When all wiring connections are complete and the field adjustments have been made, carefully insert the edge of the circuit board into the terminal strip edge card connector. Using a rocking motion, push the circuit board module into the base unit until it seats.

Use the two captive screws on the module to secure the circuit module to the base.

Attach the wall label in a conspicuous place near the TTC-1.

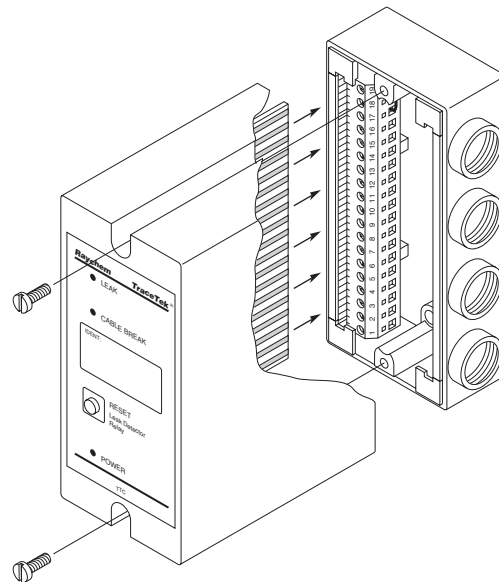

Figure 6: Module assembly

Final Check List

1. Complete a system inspection in the presence of the owner.
2. Ensure a plan showing the location of the sensor is available.
3. Check that the following information is clearly visible adjacent to the alarm module:
 - "In case of alarm" instructions
 - Location of the system map in case it is not installed adjacent to the alarm module
 - Name and contact number of the person responsible for operating the system
 - Supplier's contact name and address
4. Give these Installation, Operating and Maintenance Instructions to the owner.
5. Make the owner aware that it is strongly recommended to perform a systems check at regular intervals, at least every six (6) months.

TTC-1 Sensing Module Installation, Operation and Maintenance Instructions

Operating Instructions

System Operation

The TTC-1 module and attached sensor cable continuously monitors for liquid contact and wire breakage. LEDs on the cover of the enclosure indicate the status of the system. Relay contacts react to leak detection as well as trouble conditions:

Normal Mode Indications:

| | |
|----------------------|-----------------------|
| LEAK LED | OFF |
| CABLE BREAK LED | OFF |
| RESET BUTTON | OFF |
| POWER LED | ON (green) |
| LEAK DETECTION RELAY | NORMAL (de-energized) |
| TROUBLE RELAY | NORMAL (energized) |

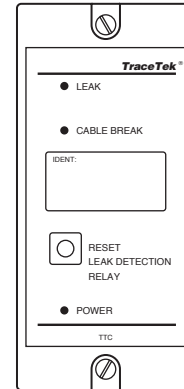

Figure 7: TTC-1 front panel

Leak Detection Indication:

| | |
|----------------------|-----------------------|
| LEAK LED | ON (red) |
| CABLE BREAK LED | OFF |
| RESET BUTTON | ON (red) (See Note 1) |
| POWER LED | ON (green) |
| LEAK DETECTION RELAY | ALARM (energized) |
| TROUBLE RELAY | NORMAL (energized) |

User Action:

1. Press RESET to return Leak Detection relay to NORMAL position.



CAUTION: Any equipment that has been automatically shut down by the Leak Detection relay may be re-activated when RESET is pushed.

2. Locate the spill area, investigate the cause of the spill and take the necessary repair actions.
3. Clean up in the spill area and clean and dry the cable if necessary. LEAK LED will turn off when cable is dried.

Cable Break Indication:

| | |
|----------------------|-----------------------|
| LEAK LED | OFF |
| CABLE BREAK LED | ON (yellow) |
| RESET BUTTON | OFF |
| POWER LED | ON (green) |
| LEAK DETECTION RELAY | NORMAL (de-energized) |
| TROUBLE RELAY | ALARM (de-energized) |

User Action:

1. Investigate the sensor cable and leader cable for physical damage. Check connectors for damage. Make repairs or replace components as necessary.
2. CABLE BREAK LED automatically turns off when full sensor cable continuity is restored.
3. TROUBLE relay automatically returns to the NORMAL position when cable continuity is restored.

Power Failure Indication:

| | |
|----------------------|-----------------------|
| LEAK LED | OFF |
| CABLE BREAK LED | OFF |
| RESET BUTTON | OFF |
| POWER LED | OFF |
| LEAK DETECTION RELAY | NORMAL (de-energized) |
| TROUBLE RELAY | ALARM (de-energized) |

User Action:

1. Investigate power wiring and connections, circuit breakers, etc. to determine cause of power loss. Make repairs as necessary to restore power to the TTC-1.
2. POWER LED turns on automatically when power is restored.
3. TROUBLE relay returns to NORMAL position when power is restored.

Note 1: The RESET Button/LED is turned on when a leak is first detected. Pushing the RESET button will cause the Leak Detection relay to return to the NORMAL condition and the red LED in the RESET button to turn off. RESET will work regardless of whether the cable is wet or dry.

TTC-1 Sensing Module Installation, Operation and Maintenance Instructions

Field Adjustments and Maintenance

Time Delay Adjustment

The leak alarm relay can be adjusted for time delay range up to 2 minutes. The purpose of the time delay is to prevent the alarm relay from activating on short term transient conditions caused by air conditioner start-up. The factory default setting is zero delay.

The adjustment screw is accessed through the rear cover plate when the TTC-1 control head is removed from the base unit. (See Figure 8). Rotate the time delay adjustment screw in the clockwise direction to increase time delay.

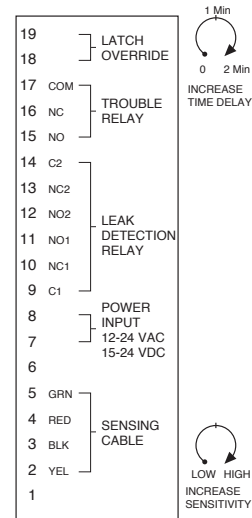

Figure 8: Location of adjustment controls

Sensitivity Adjustment

The sensitivity adjustment refers to the size of the liquid leak which will trigger a response from the TTC-1 module. The factory default setting will cause the TTC-1 to respond to a puddle of tap water approximately 8 cm (3 inches) in diameter.

The sensitivity adjustment screw is accessed through the rear cover plate when the TTC-1 control had is removed from the base unit. See Figure 8.

Sensitivity can be increased by rotating the adjustment screw in the clockwise direction and decreased by rotating the screw in the counter clockwise direction. The sensitivity control has very little effect on TT5000 or TT5001 sensors since these cables act more like ON/OFF switches.

Leak Detection Relay Latch Function

The TTC-1 default setting causes the Leak Detection relay to latch in the ALARM condition when a leak is first detected. Resetting the relay to the NORMAL condition is a manual operation that occurs when the user pushes the RESET push-button.

In some installations it may be desirable to have the Leak Detection relay track the sensor cable conditions. (I.e. RELAY in ALARM mode if the cable is wet and RELAY automatically reset when the cable dries out). This alternative configuration causes the Leak Detection relay to track the cable condition and no user interaction is required.

To enable automatic relay tracking (and defeat the latch function), remove the small jumper wire between terminal 18 and 19. See Figure 8.

Periodic Maintenance and Test

Recommended Interval: Perform a functional check per the following procedures at 6 month intervals. Repair or replace all damaged wiring and sensor cables. There are no field repair procedures for the TTC-1 module. **If the module fails to perform the functional tests, it must be replaced.**

Test Procedure:

- 1. Normal Operation:** Look for Green POWER LED
- 2. Leak Simulation:** For systems using TT1000 or TT3000 sensor cable, use a TraceTek Mapping Tool or a small container of water to simulate a leak. After the time delay has expired (maximum 2.5 minutes) look for the following indications:
 - Red LEAK LED on
 - Red RESET pushbutton on
 - Green POWER LED on
 - Leak Detection Relay in ALARM condition (Note: This may cause equipment shut down if devices are connected to the ALARM relay contacts)

After above conditions are observed:

- Press RESET
- Red LED in RESET Pushbutton turns off
- LEAK RELAY returns to NORMAL condition.

Remove simulated leak:

- Red LEAK LED goes out

For TT5000 and TT5001 systems, simulate a leak condition by tightly bending and holding the sensor cable.

- 3. Cable Break Simulation:** For any sensor system, disconnect any sensor connector in the system. Look for the following indications:

- Yellow CABLE BREAK LED on
- TROUBLE RELAY in ALARM condition

Restoring the connection should cause the TTC-1 to return to the normal indications.

TTC-1 Sensing Module Installation, Operation and Maintenance Instructions

Troubleshooting Guide

Problem: Leak Alarm, but no leak found.

Possible Cause: Cable is dirty (TT1000, TT3000)

Action: Clean cable using water. Dry the cable and check TTC-1 front panel. Heavily contaminated cable may require replacement. Sensitivity can be adjusted to a lower level, but if dirt is accumulating, cleaning and/or replacement will eventually be required regardless of sensitivity setting.

Problem: Leak Alarm, but no leak is found.

Possible Cause: Cable is exposed to occasional water (TT1000, TT3000)

Action: Increase time delay and/or reposition cable further from the intermittent source of water. It is best to keep the sensor cable at least 3 feet from the outflow of any air conditioner units.

Problem: Leak Alarm, but no leak is found.

Possible Cause: Cable is in contact with sharp metal edges (TT1000, TT3000)

Action: Check the sensor cable for possible points of contact with sharp edges such as the edges of drip pans or the pipe threads on adjustable floor supports. Reposition the cable as necessary or insert a small piece of insulating material to prevent the cable from making contact with the metal edge.

Problem: Leak Alarm, but no leak is found.

Possible Cause: Cable is pinched (all cables)

Action: Check the sensor cable for possible pinch points. TT5000 and TT5001 can be tripped if tightly bent or compressed by a heavy object. TT1000 and TT3000 can be tripped by heavy pressure from a metallic object. Check the entire cable installation for pinch points and correct the condition.

Problem: CABLE BREAK indication but cable appears to be intact.

Possible Cause: Loose connections at terminal block.

Action: Check all terminal block screws for tightness. To test the module by itself, use two small pieces of wire to form temporary jumpers from red to green and yellow to black at the sensor cable terminal block. This simulates a very short piece of sensor cable and the yellow CABLE BREAK LED should go off. If the TTC-1 cannot pass the jumper wire test, it may require replacement.

Problem: PLC or other host system detects a fault when the TTC-1 is operating in NORMAL mode.

Possible Cause: Loose connections at terminal block or broken wires between TTC-1 and PLC.

Action: Check all terminal block screws for tightness. Many installations use a normally closed contact to indicate a normal condition at the TTC-1. If the wiring between the TTC-1 and the PLC is loose or open, then the host system will read the open circuit as a fault regardless of the TTC-1 status.



Note: Cable Cleaning

TraceTek 1000 and TT3000 use a solid core polymer construction and can usually be easily cleaned with tap water. In extreme cases or when large amounts of cable are contaminated, these cables can be washed in an ordinary dishwasher. Try a water only (no detergent) cycle first and avoid the heated dry cycle. When placing the cable in the dishwasher be sure to tightly connect the male connector on one end to the female connector on the other in order to keep water out of the connectors.

TT5000 and TT5001 cannot be cleaned without special equipment. These cables normally require replacement after exposure to fuel or solvent

Tyco and TraceTek are trademarks of Tyco Thermal Controls LLC or its affiliates.

Worldwide Headquarters
Tyco Thermal Controls
 300 Constitution Drive
 Menlo Park, CA 94025-1164
 USA
 Tel (800) 545-6258
 Fax (800) 527-5703
 info@tycothermal.com
 www.tycothermal.com

Important: All information, including illustrations, is believed to be reliable. Users, however, should independently evaluate the suitability of each product for their particular application. Tyco Thermal Controls makes no warranties as to the accuracy or completeness of the information, and disclaims any liability regarding its use. Tyco Thermal Controls' only obligations are those in the Tyco Thermal Controls Standard Terms and Conditions of Sale for this product, and in no case will Tyco Thermal Controls or its distributors be liable for any incidental, indirect, or consequential damages arising from the sale, resale, use, or misuse of the product. Specifications are subject to change without notice. In addition, Tyco Thermal Controls reserves the right to make changes—without notification to Buyer—to processing or materials that do not affect compliance with any applicable specification.