

Raychem

**TraceTek
Long-Line and Zone
Leak Detection and Location Systems**

Operation and Maintenance Manual

For TTDM-1, TTDM-2, and TTDM-24
Alarm and Locating Modules

A

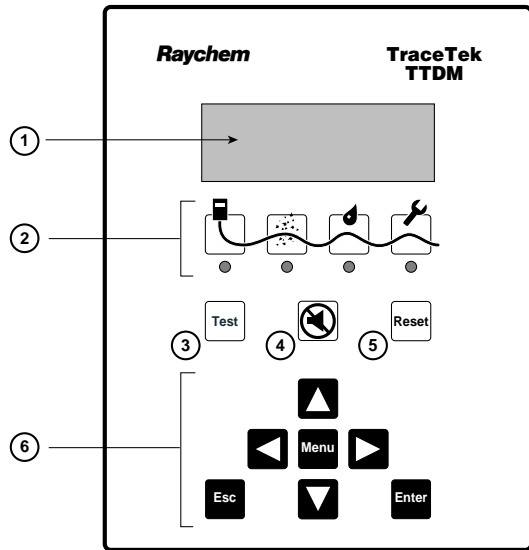

B

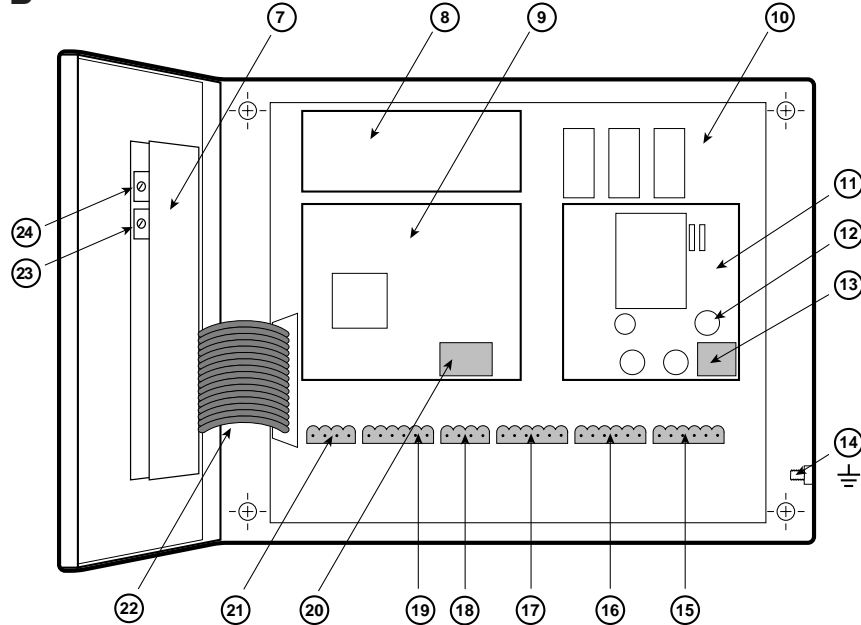

Identifying TTDM Features

External View [A]

- (1) LCD display gives up-to-date information regarding the condition of the system.
- (2) Icons and LEDs (light emitting diodes):

| | |
|------------------------|--------|
| Monitoring LED | green |
| Service (Required) LED | yellow |
| Leak LED | red |
| Fault LED | red |
- (3) (Self) Test key
Can be used at any time to verify the correct operation of the module. The module performs a series of self-diagnostic checks.
- (4) Silence key
Used to silence audible alarms
- (5) Reset key
Used to reset the leak alarm relay after a leak has been cleared.
- (6) Menu keys
The menu button provides access to various features that may be viewed and/or edited. The menus are navigated with the arrow keys together with the Esc (escape) and Enter keys.

Internal View [B]

- (7) User interface board
- (8) 4–20 mA board
- (9) Sensor interface board
- (10) Motherboard
- (11) Power supply board
- (12) Fuse (200 mA, 250 V)
- (13) Power cable terminal block
- (14) Ground (earth) stud
- (15) Fault relay cable plug and socket
- (16) Leak relay cable plug and socket
- (17) Service relay cable plug and socket
- (18) 4–20 mA port plug and socket
- (19) RS-232/485 port plug and socket
- (20) Sensing cable plug and socket
- (21) Reserved for future use
- (22) Ribbon cable
- (23) Volume adjustment
- (24) LCD contrast adjustment

Introduction

Please read before use

Please read these instructions carefully and keep in a safe place (preferably close to the module) for future reference.

The instructions provided in this booklet must be followed carefully to ensure proper operation. If the equipment is used in a manner not specified by the manufacturer, the protection provided by the equipment may be impaired.

Description

The TTDM module has been specifically designed for use with TraceTek sensing cables (all TT1000, TT3000, and TT5000 series sensing cables, and all TT100, TT300, and TT500 series long-line sensing cables). TTDM can monitor up to 5000 ft (1500 m) of sensing cable and can detect and locate the presence of liquid at any point along the cable. The module also monitors the system for other alarm conditions:

- Service required
- Fault

Each “event” (service, leak, or fault) is recorded in an Events History with the time and date of occurrence. This allows easy tracking of events.

Preparation

Before operation, the instructions in the “TTDM Installation Instructions” that accompany the system must be followed so that the module is properly:

- Mounted
- Powered (wired and energized)
- Connected to a TraceTek sensing cable with a TraceTek jumper or leader cable
- Commissioned (a completed commissioning form should be supplied)

If these steps have not been taken, please refer to the “TTDM Installation Instructions” in order to complete the installation.

In addition, there should be a system map, which indicates the sensing cable layout with reference landmarks throughout the system.

Notes

- Throughout this manual, the examples shown use distances in feet.
- Later versions of software may provide new features and change certain other details. This manual documents UI Version 1.05.

Contents

| | |
|--|-----|
| Identifying TTDM Features | ii |
| Introduction | iii |
| Leak Detection System Description | 2 |
| Connection to Other Devices | 4 |
| The Basic Events | 6 |
| Leak Detection and Location Events | 8 |
| Service Events | 10 |
| Fault Events | 12 |
| Multiple Events | 14 |
| Navigating the Menu Structure | 18 |
| The Events History Log | 19 |
| Diagnostics (System Status) | 20 |
| Changing Settings (View/Edit Settings) | 22 |
| Appendix 1 - Menu Structure | 25 |
| Appendix 2 - Events Glossary | 26 |
| Appendix 3 - Maintenance | 28 |
| Appendix 4 - Interface Details | 30 |
| Appendix 5 - Wiring Details | 32 |
| Appendix 6 - TraceTek Technical Data | 33 |

Leak Detection System Description

TraceTek Longline System

A TraceTek longline system provides distributed leak detection and location to monitor long lengths and wide areas. The system consists of the TTDM Alarm and Locating Module and up to 5000 ft (1500 m) of sensing cable.

The sensing cable detects liquid at any point along its length. The module then signals the alarm and displays the distance to the leak.

The longline system includes sensing cable and circuit components (leader cable, jumper cables, end terminations, weighted lengths, and branching connectors) with connectors that allow components of the system to plug together.

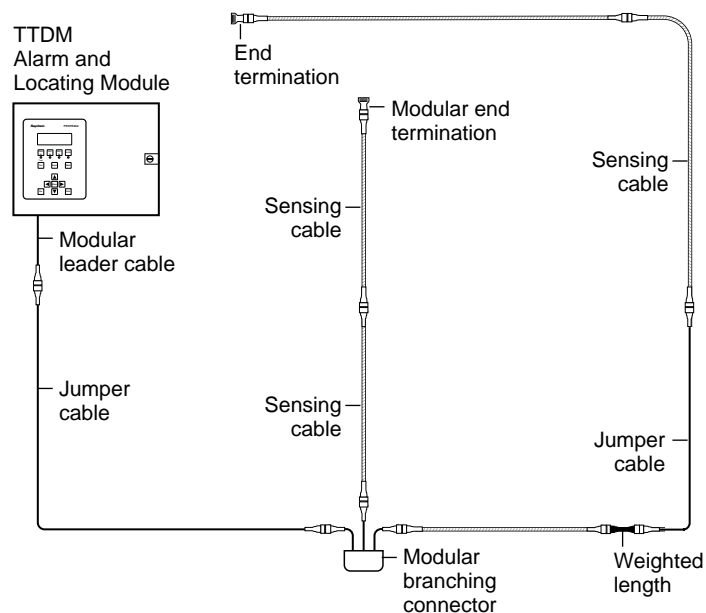

The **weighted length** resistor simulates a 15 ft (5 m) length of sensing cable. Installed at the boundary between two areas, it allows the user to clearly identify the area where the leak has occurred.

The **branching connector** enables the sensing cable to be branched. An **end termination** completes each branch. At the branching connector, the system first counts the sensing cable along the branch (middle connector), before it continues with the main run. Two built-in 15 ft (5 m) weighted length resistors allow the user to clearly identify on which leg a leak has occurred near the branching connector.

An important part of the TraceTek longline system is the system map, a sensing cable layout plan with actual distance readings. Thus, in case of an alarm, the location of the event can be determined quickly. The map should be placed near the Alarm and Locating Module.

The TraceTek Zone System

The TraceTek zone system is a leak detection and location system that monitors many separate locations from one point. The zone system consists of the TTDM Alarm and Locating Module and up to 100 separate sensing zones interconnected by one run of jumper cable.

Each sensing zone consists of a zone connector and one 5 ft (1.5 m) length of sensing cable. If liquid is detected, the module signals the alarm and displays the zone where the leak has occurred. The zones are numbered sequentially by the system electronics.

Important: In a TraceTek zone system, only **zone** sensing cables (TT3000 zone or TT5000-series zone) may be used. Each sensing cable plugs into a zone connector. The last zone connector must have an end termination.

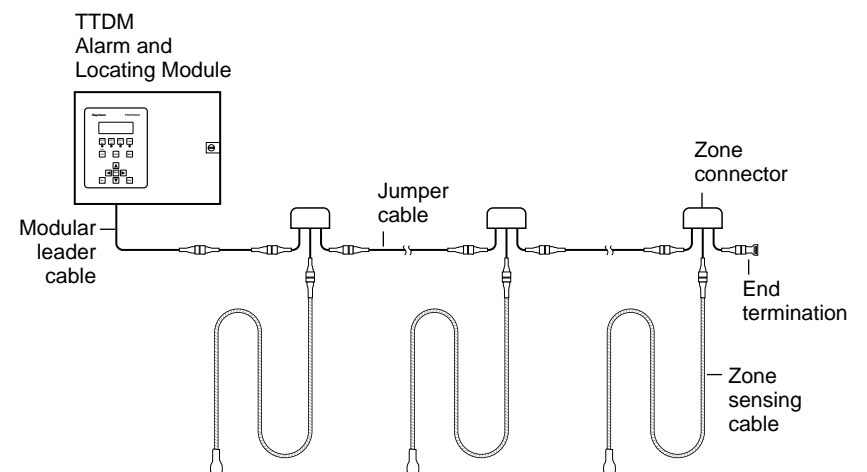

Connection to Other Devices

Relays

TTDM has three relays:

- Service
- Leak
- Fault

Each relay provides two Form-C relay contacts, with normally open and normally closed contacts both provided. The relays are **de-energized to indicate an alarm** condition. The diagram below shows the relay status when each is in an alarm (de-energized) state.

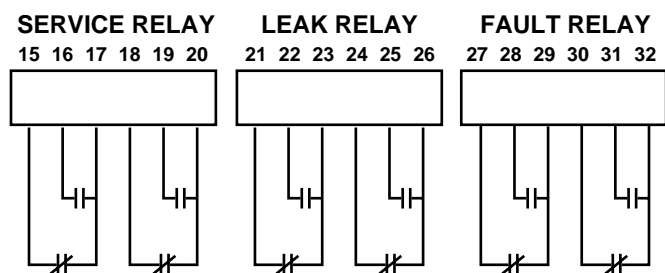

(For other connection options, please consult Appendix 5 - Wiring Details.)

4–20 mA

The module is equipped with an analog 4–20 mA interface. The TTDM adjusts its current output based on whether an alarm condition exists, and (when a leak is detected) the location of the leak. Its output can be scaled to make full use of the 4–20 mA range for the length of sensing cable connected.

Note: The current transmitter is isolated from the sensing circuitry and therefore requires an external 24 Vdc power supply.

The 4–20 mA output port (18 on foldout) is connector J2 on the TTDM motherboard, with terminals as noted in the following table:

| Pin | Desc. | Use |
|-------|-------|--------------------------|
| J2-11 | IRTN | Current loop return |
| J2-12 | IOUT | Current output |
| J2-13 | +V | 24 Vdc supply (required) |
| J2-14 | +VRTN | 24 Vdc common (required) |

Note: More information about operation and testing is found in Appendix 4 - Interface Details.

Serial Port

The TTDM module has a serial port (marked EXT COM PORT) that can be configured for use either as an RS-232 or RS-485 transceiver. The factory default is RS-232, and is suitable for connecting the TTDM to single devices up to 50 ft (15 m) away. The standard configuration is RS-232 full-duplex with no hardware handshaking, which is suitable for connection to many devices (such as a remote host PC, laptop, or modem).

The RS-232/485 port (19 on foldout) is connector J13 on the TTDM motherboard. The pinouts for connector J13 on the TTDM motherboard are listed below, with functions for RS-232 usage noted.

| Pin | Desc. | Use |
|--------|---------|---|
| J13-5 | RX/A | Receive data |
| J13-6 | TX/B | Transmit data |
| J13-7 | RTS | Request to send — for hardware handshaking |
| J13-8 | CTS | Clear to send — for hardware handshaking |
| J13-9 | +5V/DTR | +5V supply/DTR if needed by modem |
| J13-10 | GND | Supply return |

Note: For further information, see Appendix 4 - Interface Details.

The Basic Events

The Icons

The Icons (2 on foldout) represent the four main states of the TTDM module:

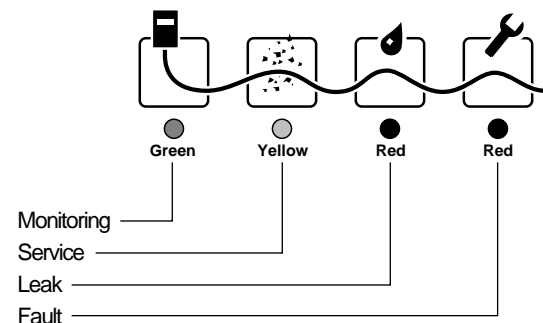

Monitoring

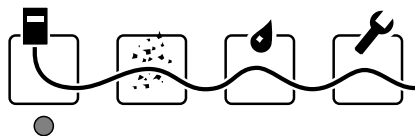

This green LED indicates that the TTDM is monitoring the sensing cable. If something happens that makes it impossible for the TTDM to monitor the sensing cable (for example, the cable is broken), the Monitoring LED will extinguish.

Service

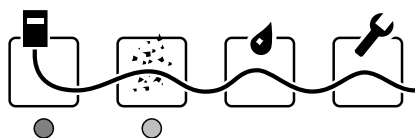

The TTDM is able to give advance warning of potential problems. This yellow Service LED illuminates to indicate that service is required. Note that the green LED remains illuminated; the unit continues to monitor for leaks during a Service alarm.

See the “Service Events” section on page 10 for further details.

Leak

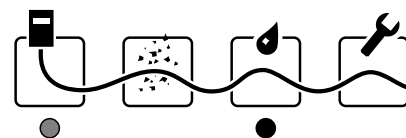

When liquid is detected on the sensing cable, this red Leak LED illuminates. Note that the green LED remains illuminated; the unit continues to monitor for leaks and spills. This is covered more fully in the following section “Leak Detection and Location Events”, on page 8.

Fault

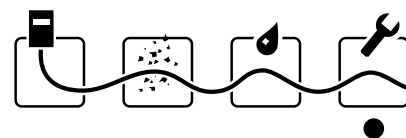

When the TTDM module detects a fault—either a cable fault, or an electronics fault—it lights this red LED. Note that in a Fault condition, the TTDM module is unable to detect a leak. For further information, see the “Fault Events” section on page 12.

LCD Display

```
Leak 10 ft
Leak Cleared
Press Reset
16:30 14-Feb-1996
```

Line 1 indicates the original location of a leak.

Line 2 indicates the present status (except when a leak is initially detected, since the initial location is always shown on line 1).

Line 3 may advise action or provide special instructions.

Line 4 displays the current time and date (the colon blinks once a second). To highlight the present status, the line of the display with the most recent event flashes.

Hint: The LCD contrast may be adjusted (24 on foldout).

Leak Detection and Location Events

If the TTDM unit has been installed correctly, and the system is clear, the LCD display will appear as follows:

```
System Normal
15:53 14-Feb-1996
```

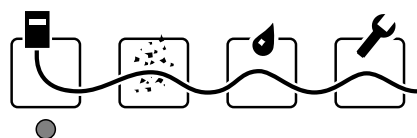

Leak

When liquid is detected, the following occur:

- The audible alarm sounds.
- The red Leak LED illuminates.
- The interfaces (relays, 4–20 mA, serial port) respond.
- The display changes to show the location of the leak:

```
Leak 10 ft
16:00 14-Feb-1996
```

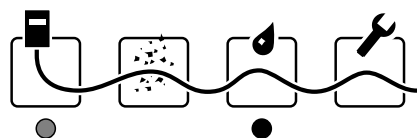

The following actions should be taken:

- Silence the alarm.
- Locate the leak.
- Clear the system.
- Reset the leak relay.

To Silence the Alarm

Press the Silence key to silence the audible alarm.

Hint: If audible alarms are not required, the module can be set to disable them (see “Audible Alarm” under “Leak Settings” on page 23).

To Locate the Leak

Using the number displayed by the TTDM, refer to the system map and determine where the leak was detected.

To Clear the System

Fix the leak and cleanup the area affected. Then dry the sensing cable (in the case of TT1000 and TT3000) or replace the tripped section (TT5000 family).

Once the sensing cable is clear, the module responds and the display changes:

```
Leak 10 ft
Leak Cleared
Press Reset
16:30 14-Feb-1996
```

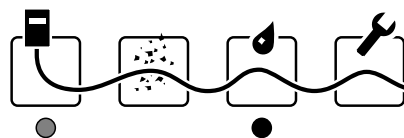

Notice that the red LED remains on. This is to indicate that the leak relay is still in the alarm state.

To Reset the Leak Relay

In order to reset the leak relay and return the module to the “System Normal” state, press the reset button. Before doing so, check that any external or remote equipment controlled by the TTDM is ready to be reset.

Hint: If manual reset is not required, the module can be set to auto-reset (see “Auto-Reset” under “Leak Settings” on page 23).

Once the Reset button is pressed, the relay returns to normal, the red Leak LED extinguishes, and the LCD display changes:

```
System Normal
16:53 14-Feb-1996
```

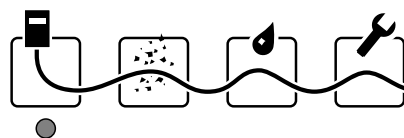

Service Events

Introduction

A TraceTek sensing circuit consists of two electrical loops (a diagram of the sensing circuit is shown in Appendix 6). The TTDM module constantly monitors to see whether current is passing between the loops. When the system is normal, there is no current passing between the loops. When there is a leak on the system, the maximum current flows (just 270 μ A; the sensing cable operates on low voltage and is safe to touch).

If, however, the TTDM module detects a lower but significant level of current flow between the loops, it activates the Service alarm.

A low-level current could indicate one or more of the following:

- A very small leak (which may soon develop into a full leak alarm).
- Heavy condensation or small spills (coffee, tea, etc.) on a water-sensing or aqueous-chemical-sensing cable (TT1000 and TT3000).
- Conductive material on a water-sensing or aqueous-chemical-sensing cable. The material might be metal filings, concrete dust, flux, mastic, or other construction debris, or carbon-based dust from air-handling units, printers, or copiers.

While it is recommended that service alarms be investigated, the operation of the system is not threatened; the TTDM will continue to detect leaks. However, the accuracy of location may be affected in certain cases.

The Service Alarm

When a condition requiring service (such as described above) is detected, the following occur:

- An intermittent beep sounds.
- The yellow Service LED illuminates.
- The service relay goes to alarm condition.
- The LCD display changes to the following:

```
Service Req'd [11]
15:53 14-Feb-1996
```

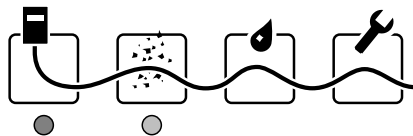

The number in square brackets indicates the estimated location of the material causing the alarm. The number is shown with square brackets to indicate that the value is only an estimate.

Hint: Because the cause (concrete dust for example) of low-level current may be distributed over several feet/meters of cable, it is not always possible for the TTDM to return an accurate location. However, the indicated location is always a good point from which to begin a troubleshooting procedure.

The following actions should be taken:

- Silence the audible alarm.
- Clear the cable.

To Silence the Audible Alarm

Press the Silence key to silence the alarm.

To Clear the Cable

Investigate the cause of the alarm and conduct cleanup or maintenance accordingly.

Hint: If material causing a service alarm is spread throughout the system, it is often useful to subdivide the system; see Appendix 3 - Maintenance, for further information.

When the material (such as moisture or concrete dust) or conditions causing the alarm are removed, the yellow LED goes out, and the service relay returns to its normal state:

```
System Normal
16:57 14-Feb-1996
```

Fault Events

Introduction

Several conditions could lead to a fault alarm:

- A cable is disconnected.
- A cable is damaged.
- A connection is damaged.
- There is a problem with the module.

What the Module Does

The following shows how the alarm display would appear if the fault were caused by a broken or disconnected cable. (The TTDM would display a different message for a different type of fault, such as a loss of continuity in only one of the sensing loops):

```
Cable Break
17:53 14-Feb-1996
```

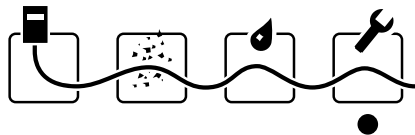

When a fault condition is detected, the following occur:

- An audible alarm sounds.
- The green Monitoring LED turns off (no longer able to detect a leak).
- The red Fault LED turns on.
- Interfaces react.

The following actions should be taken:

- Silence the audible alarm.
- Remedy the problem.

To Silence the Audible Alarm

Press the red Silence key to silence the alarm.

To Remedy the Problem

Find the problem and rectify. This may mean reconnecting the cable, or finding the damaged section and replacing it. If the cause of the fault is not obvious by visual inspection, it is often useful to subdivide the system and test individual sections with a TraceTek Portable Test Box.

As soon as the fault is rectified, the relay, LED, and LCD screen return to their normal state:

```
System Normal
15:53 14-Feb-1996
```

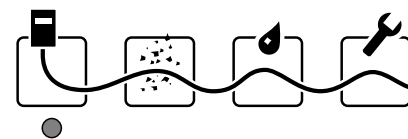

Multiple Events

In addition to storing all events in memory, TTDM gives a direct indication of multiple events, that is, events which happen after an initial leak but before the module is manually reset.

The first line of the display always indicates where the liquid was first detected. This location is the most useful in identifying the source of the leak.

The second line displays the most recent event. For example:

```
Leak 11 ft
Re-Alarm 20 ft

15:53 14-Feb-1996
```

The second line flashes to highlight the present status. If the cable is then disconnected, the display will change again:

```
Leak 11 ft
Cable break

15:53 14-Feb-1996
```

Notice that the first line remains unchanged. The second line changes to reflect the present condition of the system.

Moving Leak

The TTDM continues to monitor during “service” and “leak” alarms, ensuring that the installation is afforded full-time protection.

The TTDM will re-alarm when the leak moves more than the re-alarm distance, for which the default is 5 ft (1.5 m). The audible alarm will sound, the second line of the LCD will change, and a new event will be added to the Events History.

Example:

Suppose a leak is detected at 50 feet:

```
Leak 50 ft

15:59 14-Feb-1996
```

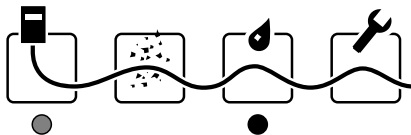

Example (continued):

Before the problem can be dealt with, the leak spreads. Once the module has detected significant movement (that is, greater than the Re-Alarm distance—see “Re-alarm distance” on page 23 for more detail), the module goes into alarm once again:

```
Leak 50 ft
Re-Alarm 55 ft

16:01 14-Feb-1996
```

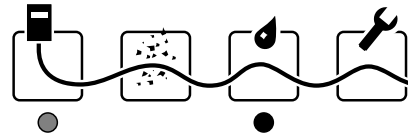

The LCD now displays the FIRST leak and the MOST RECENT alarm. The FIRST recorded leak is likely to be close to the source of the leak.

The MOST RECENT leak shows the current “electrical center” of the liquid (essentially a weighted average). If the re-alarm number is close to the first (as in the example above), it is likely that the leak has spread.

Should the leak continue to spread, the TTDM would re-alarm again; the second line is updated again:

```
Leak 50 ft
Re-Alarm 60 ft

16:23 14-Feb-1996
```

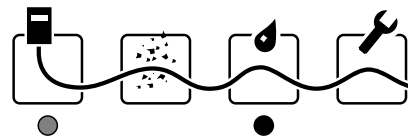

Hint: Use the Events History to track the events between the “first leak” and the “most recent event.” See “The Events History Log” section on page 19.

Additional Leak

If liquid contacts the sensing cable away from the initial leak, the module will re-alarm. If the location is distant from the last alarm, the TTDM shows a location in square brackets. Brackets indicate that the value shown requires interpretation; when an additional leak occurs, the value represents the “electrical center” of the leaks.

```
Leak 50 ft
Re-Alarm [1045]

15:53 14-Feb-1996
```

The display also prompts the user to check the Events History log in order to investigate the sequence of events between the first leak at 50 ft, and this re-alarm event.

Service-to-Leak Alarm

Case 1 - Different locations

Although TTDM can continue to monitor when a Service Required alarm is in effect, the accuracy of location may be impaired. TTDM indicates this by displaying the leak location in square brackets.

Example:

```
Service Req'd[2003]

15:53 14-Feb-1996
```

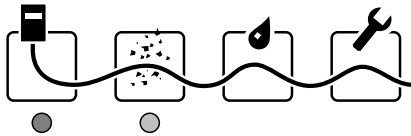

If a leak contacts the sensing cable before service was performed, the display would appear as below:

```
Leak [50]

15:53 14 Feb 1996
```

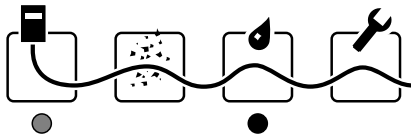

Note how this leak event differs from the simpler leak event detailed on page 8:

- Rather than displaying the message “Leak 50 ft,” the display puts the location in square brackets. This indicates that 50 ft is the likely location of the leak.

Case 2 - Service, then leak at same location

If a leak is detected at nearly the same location as that causing a Service Required alarm, TTDM operates differently, as shown below.

First, there is an alarm for Service Required.

```
Service Req'd[237]

16:53 28-Feb-1996
```

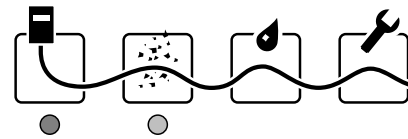

Subsequently, a full-fledged leak is detected at nearly the same location. The TTDM responds as shown below:

```
Leak 239 ft

17:45 28-Feb-1996
```

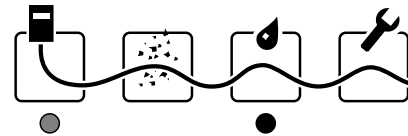

Since the Service Required alarm was at the same location, it is interpreted as an early indication of the leak. The TTDM therefore clears the service alarm, and displays the leak location without brackets.

Navigating the Menu Structure

Please refer to “Appendix 1 - Menu Structure” on page 25 for an overview of the menu structure and to item 6 on the foldout for the menu keys which are also shown below:

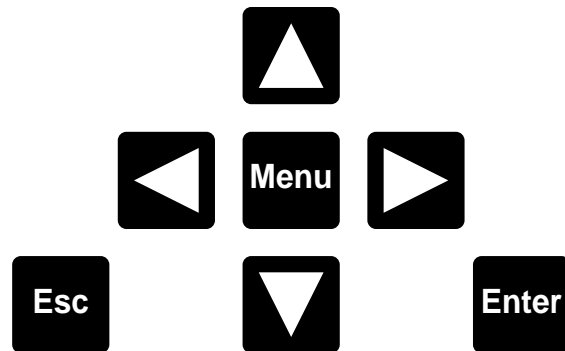

Start by pressing the **Menu** key.

Use the four **arrow** keys to scroll through menu items, and to select individual characters.

To go one level deeper into the menu structure, press **Enter**.

To go back one level in the menu structure, Press **Esc**.

The Scroll Bar

The scroll bar (see example below) indicates that there is more information off screen; the arrow indicates the direction of further information:

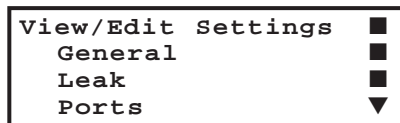

The Events History Log

One extremely useful function provided by TTDM is the ability to record a series of events. The TTDM module keeps track of a list of 512 events.

For a full list of event types, please refer to “Appendix 2 - Events Glossary” on page 26.

Accessing the Events History Log

- Press **Menu**.
- Select **Events History** (scroll down with the down arrow key).
- Press **Enter**.

The most recent (that is, current) event is displayed:

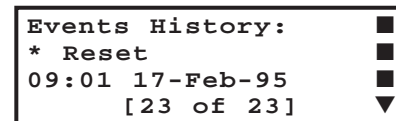

The arrow at the bottom right-hand corner indicates that there are further events 'below' (= before) this one. The bottom line of the display indicates that the unit has recorded 23 events, and the one displayed is the most recent event.

- Press **Down Arrow** key. The previous event is displayed:

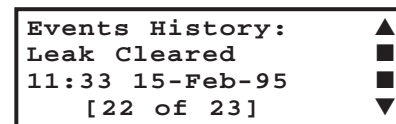

- Press **Down Arrow** key again. The third from last event is displayed:

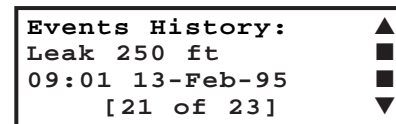

Hint: To quickly move to a view of the most recent event, press the **Right-Arrow** key. To move to the oldest event, press the **Left-Arrow** key.

The TTDM can store up to 512 events. If 512 events are already stored, the oldest event is discarded as a new event is registered. When this has occurred, the Events History leaves the bottom line of the display blank. Contact Raychem for assistance if you wish to clear the event history.

Diagnostics (System Status)

System Status

System Status provides a real-time view of the system. You gain access to this feature through the main menu. When System Status is selected, the TTDM displays the following screen (the “{system status}” entry on the second line is explained below):

```
System Status:      ■
{system status}    ■
Test Length 4785 ft■
Location  ----- ft▼
```

The arrow at the bottom right indicates other entries can be accessed with the down arrow key. The complete list of information available in System Status is shown below:

```
System Status
{system status}
Test Length 4785 ft
Location ----- ft
Current      0 μA
R S-to-S    ----- kΩ
R RG Loop   18658 Ω
R YB Loop   18656 Ω
SI Version  100
UI Version  105

R Loc       0 Ω
SI Status   1024
UI Status   1024
SI Comm     100
```

“{system status}”

This is a variable field, which can contain any of the following text, depending on the state of the system:

- System normal
- Leak
- Re-alarm
- Service Required
- Fault (specific entries are shown in Appendix 2)

Test Length

The Test Length should be the same as that recorded when the system was mapped. If it is not, it may mean that the system was modified (sensing cable was removed or added).

Note: The Test Length is typically about 1% longer than the physical or mapped length of the system. This is normal.

Location

The current location—or electrical center—of the leak (or cause of a Service alarm). If the status is System Normal, the Location entry is blank.

Current

This current (measured in μA) indicates the condition of the sensing cable. If a leak is detected, this rises to 270 μA . In a clean, leak-free system, the current should be 5 μA or less. If the current rises above 20 μA , service is recommended, as it may indicate the presence of contamination. To better understand what this current means, see “Appendix 6 - TraceTek Technical Data”, which explains the TraceTek operating principle.

R S-to-S

This is the resistance from sensing wire to sensing wire (see Appendix 6 for detail). For a clean, leak-free system, this resistance is in the $\text{M}\Omega$ range. If liquid is detected, it drops to the $\text{k}\Omega$ range or even lower. If the value is changing, it may indicate an event in progress.

R RG Loop, R YB Loop

These are the resistances of the Red-Green and Yellow-Black loops in the TraceTek sensing circuit (see Appendix 6 for detail). If these values are significantly different from each other, it may indicate damage to a sensing cable or connector.

SI Version, UI Version

These indicate the versions of the sensor interface and user interface software that are operating.

The next line in the display was left blank intentionally because the entries that follow are unlikely to be used except for reference in troubleshooting.

R Loc

This is the resistance measured along the black sensing wire to the location of the leak (see Appendix 6 for detail).

SI Status, UI Status

These hexadecimal values indicate the current status of the Sensor Interface and User Interface, respectively, and may assist factory personnel providing diagnostic support.

SI Comm

This indicates the success rate (in percent) for communications between the Sensor Interface and User Interface boards. A value below 90% may indicate a faulty connection or damaged ribbon cable.

Changing Settings (View/Edit Settings)

You gain access to the system's settings through the View/Edit Settings Menu, which is on the main menu (see "Appendix 1 - "Menu Structure" on page 25). Four types of settings are available:

- General
- Leak
- Ports
- Self-Test

In certain parts of the menu structure, settings may be changed only after entering a password.

Entering a Password

When an attempt is made to change a restricted setting, a password prompt will appear. Proceed as follows:

- Use left/right arrow keys to move to each digit.
- Use the up/down arrows to increase/decrease the number.
- Press **Enter** when complete.

```
Password:
 0000
   ^
0000...4095
```

The module is supplied from the factory with the password 0010. However, the password may be changed if required (see the explanation under "General Settings" below).

Note: Once the password is entered, it remains in effect (allowing access) until exit from the main menu to the normal monitoring screen, or until there has been no keypad activity for 30 minutes.

Changing a Setting

When the value or selection for a setting has been changed, either:

- Press the **Enter** button to accept the change.
- Press the **Esc** button to cancel the change.

General Settings

You gain access to the General settings through the View/Edit Settings Menu, which is on the main menu (see page 25 for the menu structure).

Date/Time

Use left/right arrow keys to **select** each digit. Use the up/down arrow keys to **increase/decrease** the number.

Units

Use the cursor to select **feet**, **meters**, or **zones** as required. Note: Do not choose zones unless the system includes only zone sensing cables with zone connectors.

Language

Select from available options (English, Français,...)

Change Password

Enter the new password (using the arrow keys) and press **Enter**.

Don't forget your password! Write it down in a safe place!

Hint: If password protection is not required, set the password to 0000. After that, you will not be prompted for a password.

Leak Settings

You gain access to the Leak settings through the View/Edit Settings Menu, which is on the main menu (see page 25 for the menu structure).

Re-alarm distance

This is the distance over which the electrical center of the leak must move before TTDM will re-alarm. It can be set between 3 ft (1 m) and 20 ft (6 m); the factory default is 5 ft (2 m).

Re-alarm interval

The TTDM can be made to re-alarm automatically if a leak has not been cleared after a certain length of time. Choose from:

- Never (factory default)
- 8 hr
- 12 hr
- 24 hr

Hint: Use this to automatically alert the next shift when the system has an uncleared leak.

Auto-reset

By default, TTDM requires a manual reset following a leak event. This allows the user to, for example, verify that any equipment controlled with the Leak relay is ready to be switched back on.

TTDM can be set to "auto-reset" following a leak. In this case, the leak relay will revert to the normal state as soon as the leak has been cleared.

- Select: Auto-reset – On

Audible alarm

The audible alarm may be disabled if not required.

- Select: Audible Alarm – Off

Hint: The volume may be adjusted (23 on foldout).

Sensitivity

Select:

- “normal” sensitivity for most applications
- “high” sensitivity for de-ionized water
- “low” sensitivity for particularly active or exposed applications

Barrier Resistance

If you are using a zener barrier (or a lightning protection device) its resistance can be “dialed out” so the system map can begin at 0.

Note: Always set this value BEFORE mapping the system. Consult your Raychem TraceTek representative for further details.

Port Settings

You gain access to the Port settings through the View/Edit Settings Menu, which is on the main menu (see page 25 for the menu structure).

Baud

The serial port can be set to a variety of communications rates. The default is 9600.

Modem

This selects a menu of modem commands. Contact Raychem for additional information.

485 Address

This entry assigns an RS-485 address for the TTDM. This will allow multiple TTDM units to be networked. Contact Raychem for additional information.

Terminal

This selection provides a real-time display of communications to and from a modem or host system, which can be helpful for diagnostic purposes.

Self-Test Settings

You gain access to the Self-Test settings through the Self-Test Menu, the last item on the View/Edit Settings Menu, (see page 25 for the menu structure).

The Self-Test Menu allows individual functions to be tested, and expands on tests performed when the (self) Test key is pressed. The tests available for a function are displayed after that function is selected from the Self-Test Menu. They include:

- UI test (User Interface)
- Memory Tests
- SI test (Sensor Interface)
- Audio Test
- Display Test
- Keypad
- Relay Test
- 4–20 mA Test
- Ext Comm Loop Back Test (for serial port)

Appendix 1 - Menu Structure

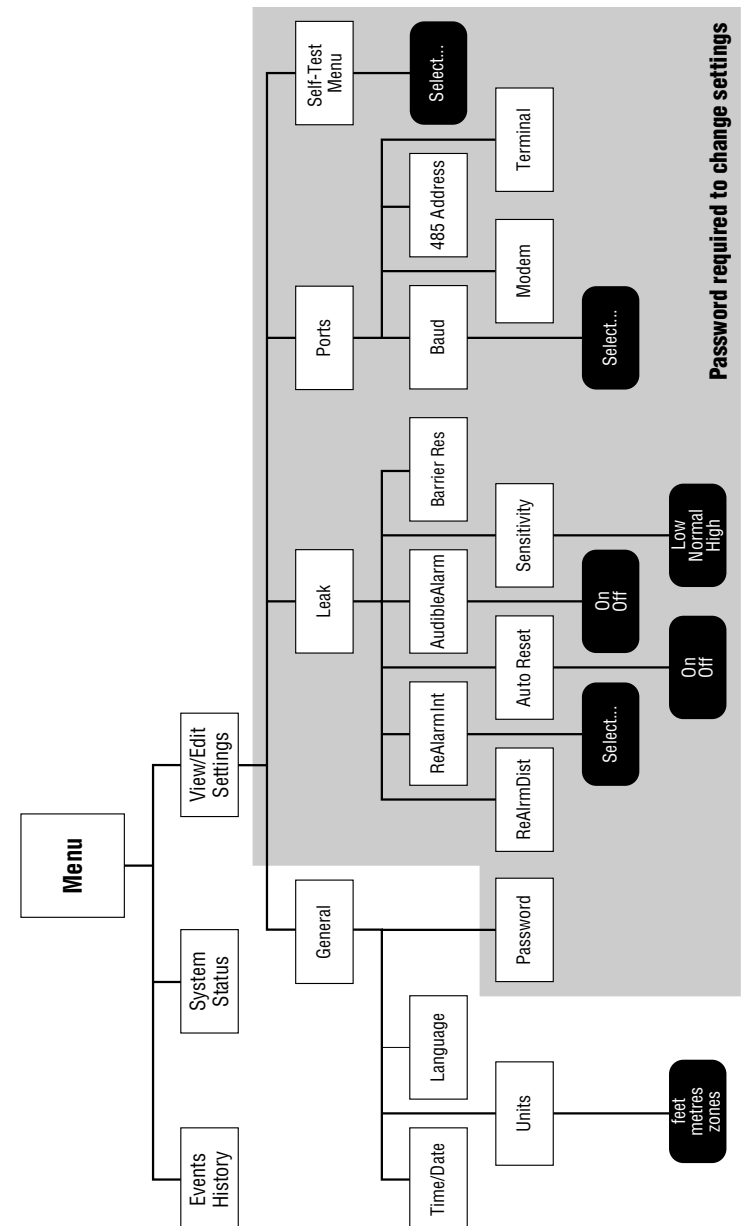

Appendix 2 - Events Glossary

| Type of Event | Message | Description |
|---------------|---------------------|---|
| Power | Power Down | The time power was last supplied is stored in nonvolatile memory, and is entered into the Events History Log when power is restored. |
| | Restart | The Events Log history records when power is supplied to the unit, or when the unit is manually restarted. |
| Leak | Leak | Liquid detected at the location displayed. |
| | Re-alarm | Occurs under three different situations: <ul style="list-style-type: none"> • Location changed past re-alarm threshold; TTDM displays most recent location (without brackets). This likely means the leak is moving (or drying). • New location detected more than 25 ft (8 m) from original location; TTDM displays most recent “average” location in square brackets. This may indicate a new leak, or a new point of contact with a serpentine cable. • Automatic re-alarm after the Re-alarm interval (a user setting) if the leak condition still exists. |
| | ✓ Leak Cleared | Displayed when cable returns to normal after leak. |
| | New Leak | A new leak has been detected after an earlier leak was cleared but not Reset. |
| Fault | Cable Break | Loss of continuity in both detection loops; may be broken or disconnected sensing cable, jumper cable, leader cable, or connections. |
| | YB Loop Break | Break in the Yellow-Black sensing cable loop. |
| | RG Loop Break | Break in the Red-Green sensing cable loop. |
| | Loop Imbalance | Resistance of the two loops differs by more than 25%; this may indicate the cable has been damaged. |
| | ✓ Cable Restored | Displayed when cable returns to normal after any of the faults noted above. |
| | SI Comm Error | Communications problem between the User Interface and Sensor Interface boards, which may be due to a faulty connection or damaged ribbon cable. |
| | ✓ SI Comm Recovered | Communications between UI and SI have been restored. |

| | | |
|--------------------|--------------------|---|
| | SI H/W Error | A self-test of the Sensor Interface Hardware has failed; the unit needs repair. |
| | ✓ SI H/W Recovered | The hardware problem has been corrected. |
| Service | Service Req'd | A small amount of current is flowing between the two sensing wires; this usually indicates something is contacting the sensing cable that should be investigated and corrected. |
| | ✓ Service Clear | The condition requiring service has been cleared. |
| User action | {Settings} Changed | When a user changes settings, the name of the setting, the time, and date are recorded in the Events History log. |
| | Alarm Silenced | |
| | Reset | |

Appendix 3 - Maintenance

Cleaning the Module

To clean the outside surface, use a damp cloth or sponge. Do not use solvents or abrasive cleaners, and do not open the enclosure while it is wet (it is an electrical device).

Fuse Replacement

The fuse on the power supply board (12 on foldout) is a 200-mA, 250-V, quick-acting microfuse. It has an F1 rating, characteristic code F (quick-acting). Use no other type of fuse or the TTDM could be damaged or could fail to perform properly.

Routine Maintenance

It is recommended that the TraceTek system be thoroughly checked twice a year. Such a check will identify conditions that adversely affect the leak-locating capability of the system. More frequent checks may be required if the sensing cable is repeatedly exposed to leaks, or if construction or repair work is done where the sensing cable may be exposed. Contact your local Raychem TraceTek representative for further information on service support.

Storage and Handling of Sensing Cable

Despite their rugged construction, TraceTek sensing cables must be handled in a manner appropriate for a sensing device or they may be damaged and require replacement. Therefore, you should follow some basic rules for storing and handling all TraceTek sensing cables:

- Store spare cable in its original container in a clean, dry place until ready for installation.
- Schedule cable installation after all mechanical, plumbing, and electrical work has been completed.
- Clean the area where the cable is to be installed, and remove any obvious debris or other sources of contamination.
- Do not solder or weld near the cable without providing protection from heat, solder flux, or weld splatter.
- Do not drop tools or floor tile on the cable; sharp and heavy objects may damage the cable.
- Avoid walking or stepping on the cable. Provide shielding (for example, a half shell of plastic pipe) where additional protection is necessary.
- Do not use tape to secure sensing cable (some tapes and adhesives absorb moisture) or use solvents that could eventually cause an alarm.
- Do not drag sensing cable through contaminants (such as pipe dope, PVC cement, solvents, oil, or dirt).

Investigating Leaks and Faults

If the location of a leak is not apparent, it is often useful to subdivide the leak detection circuit, as illustrated below. To accomplish this, it is best to have a TraceTek Portable Test Box (PTB) and an extra Modular End Termination. Contact your local TraceTek representative to obtain these products. Note that the PTB comes with instructions on its use.

To segment the system and isolate problems, find a TraceTek connection at a convenient point somewhere at the center of the detection circuit. You can then use a PTB to check one portion of the system (to verify circuit integrity, to detect the presence of liquid, and even to determine its location). If you install an end termination on the other length of cable (going back to the TTDM Alarm and Locating Module), you can use the TTDM to check the “front half” of the sensing circuit.

You can further subdivide the circuit, and even test individual lengths of cables, as shown in the third diagram below. Even the most perplexing problems can usually be isolated and resolved using this methodical approach.

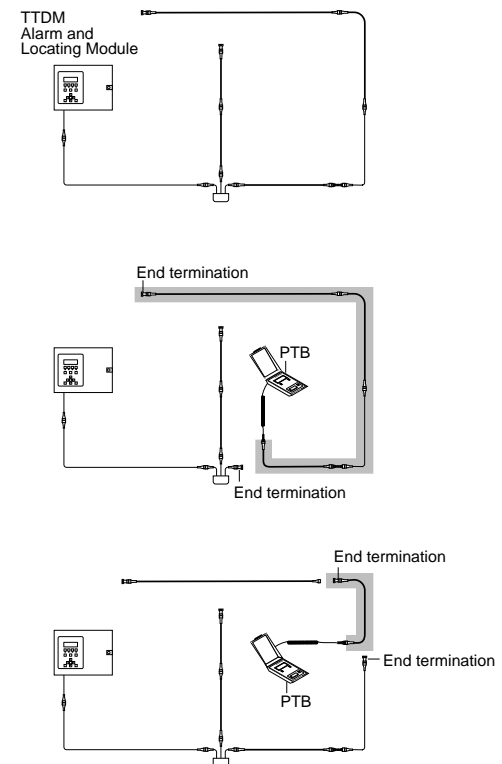

Appendix 4 - Interface Details

4–20 mA Current Transmitter

The TTDM adjusts its 4–20 mA output based on the leak detection status as detailed below.

Fault conditions:

| Output (mA) | Description |
|-------------|---|
| 0 | Electronic fault or loss of power |
| 1.00 | Fault—communications between SI and UI boards |
| 2.00 | Fault—cable break |
| 3.00 | Fault—cable damage (loop imbalance) |
| 3.50 | Service Required alarm |

Normal conditions and leaks:

| | |
|--------------|---|
| 4.00 | System normal |
| 5.00 - 20.00 | Leak; value scaled to indicate location of leak |

Testing

When external equipment is connected to the TTDM 4–20 mA output port, the current loop can be tested using the “4–20 mA Test” series under the Self-Test Menu. Before doing so, confirm that all connections have been made, including 24 Vdc to TTDM terminals 13 and 14. To conduct the 4–20 port tests, make the following menu selections, beginning from the Main Menu: “View/Edit Settings,” “Self-Test Menu,” “4–20 mA Test.” The entries in the 4–20 mA Test Menu are:

- Electronics Fault
- SI Comm Error
- Cable Break
- Loop Imbalance
- Service Req'd
- System Normal
- Leak (a submenu prompts for a location to simulate)
- 20 mA Val

All but the last entry simulate the conditions noted; the TTDM changes its current output to that designated for the condition selected (for example, 3.50 mA for a Service Required alarm).

Adjusting the Scale

Default value for the upper bound (i.e. the location that would result in the maximum current output of 20 mA) is 5000 ft. (1500 m). To change the scale, select “20 mA Val” at the bottom of the “4–20 mA Test” menu. Then enter a new upper bound to provide a reasonable scale for your system.

Important: The upper bound must be greater than the Test Length (which the TTDM displays in the System Status screen).

To confirm that the scale is acceptable, use the “Leak” option in the 4–20 mA Test menu. Simulate leaks at various locations, and verify that the output is as expected with the equipment or instrument connected to the TTDM 4–20 output port.

Note: The maximum current output can be calibrated using trimpot R7 on the 4–20 mA circuit board (8 on foldout).

Serial Port

The external communications port is configured for use as either RS-232 or RS-485. The factory default is RS-232 full-duplex with no hardware handshaking.

This is suitable for connection to a remote host PC, laptop, serial printer, or modem. With the appropriate cable and standard terminal software, a PC can receive time, communications, and Events History data.

One of the simplest but most important uses of the serial port is obtaining a printout of the Events History log with a serial printer, or a PC with communications software.

Contact your Raychem TraceTek representative for additional information to assist in connecting and configuring for serial port communications.

Connection Details

The illustration below shows the pinouts/terminals for the alarm relays, 4–20 mA port, and RS-232/485 serial port. (labeled EXT COM PORT on the motherboard)

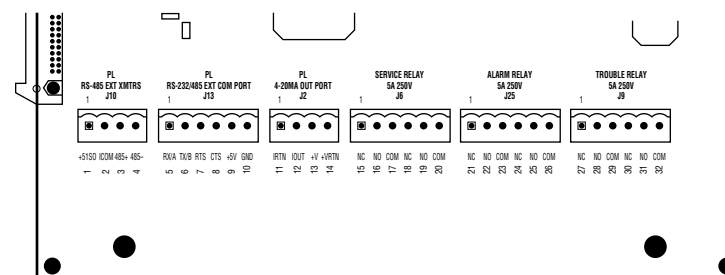

Appendix 5 - Wiring Details

Relay wiring options

The illustrations below show how relays (15, 16, and 17 on foldout) can be jumpered together to allow remote monitoring of the TTDM status with only a single pair of wires. The TTDM *de-energizes* its relays to signal an alarm condition. Therefore, loss of power as well as any other type of alarm would trip the remote alarm.

Alarm on open circuit

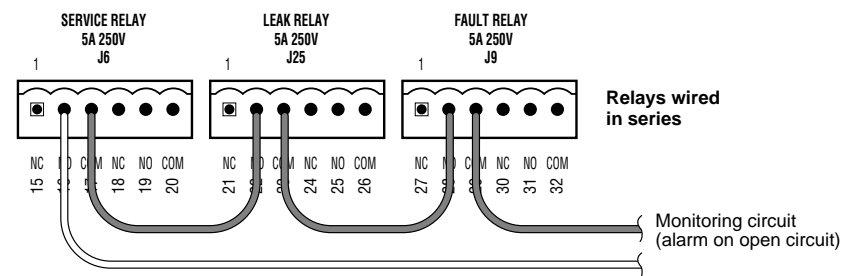

Alarm on closed circuit

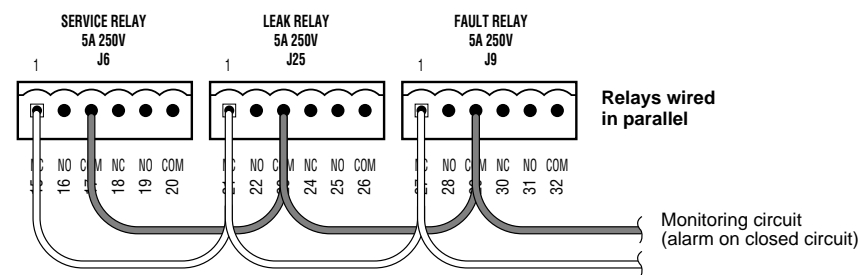

Appendix 6 - TraceTek Technical Data

TTDM Operation Diagram

Loop resistances and test length

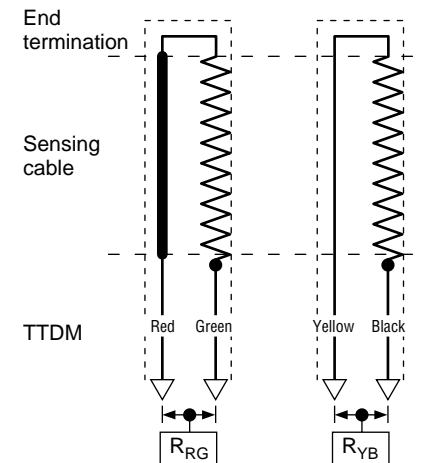

The TTDM measures resistance of each circuit loop independently to ensure the integrity of the circuit. The resistance of the yellow-black loop is used to compute the "Test Length" displayed in the System Status screen; it is based on a real-time measurement.

Leak current, resistance, location

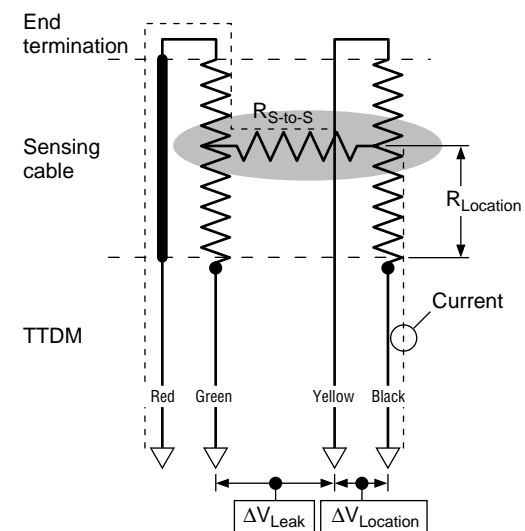

The TTDM measures current "leakage" between the two sensing loops. When a leak is present, the TTDM limits the current to 270 microamps, and measures the voltage difference between the yellow and black wires. The resistance along the black sensing wire to the leak is determined by a simple application of Ohm's law ($R = V/I$). The resistance per unit length of the sensing wire is tightly controlled in manufacturing, so this location is easily computed.

All information, including illustrations, is believed to be reliable. Users, however, should independently evaluate the suitability of each product for their application. Raychem makes no warranties as to the accuracy or completeness of the information, and disclaims any liability regarding its use. Raychem's only obligations are those in the Raychem Standard Terms and Conditions of Sale for this product, and in no case will Raychem be liable for any incidental, indirect, or consequential damages arising from the sale, resale, use, or misuse of the product. Specifications are subject to change without notice. In addition, Raychem reserves the right to make changes—without notification to Buyer—to materials or processing that do not affect compliance with any applicable specifications.

Raychem

Belgium

NV Raychem SA
Diestsesteenweg 692
3010 Kessel-Lo
Tel (32) 16/351-800
Fax (32) 16/351-797

Korea

Raychem Korea Limited
831-45 Yeuksam-Dong
Kangnam-Ku
Seoul 135-080
Tel (82) 2/ 3468-1300
Fax (82) 2/ 558-5765

United Kingdom

Raychem Ltd.
Faraday Road
Dorcan, Wiltshire SN3 5HH
Tel (44) 1793/ 572-663
Fax (44) 1793/ 572-189

United States

Raychem Corporation
Commercial & Industrial
Infrastructure Division
300 Constitution Drive
Menlo Park, CA 94025-1164
Tel (800) 545-6258
Fax (800) 611-2323
Fax-on-Demand (800) 329-4494
ciinfo@raychem.com
www.raychem.com