

# Rosemount 702 Wireless Discrete Transmitter

- An installation-ready solution that provides dual discrete, or leak detection input options
- Discrete single or dual switch input with logic for limit contact and opposing contact applications
- Flexibility to meet your most demanding applications
- Self-organizing network delivers information rich data with >99% data reliability
- WirelessHART™ capabilities extend the full benefits of PlantWeb® to previously inaccessible locations



**WirelessHART™**

## Contents

Success With Smart Wireless . . . . .	page 2
WirelessHART... The Industry Standard . . . . .	page 3
Ordering Information . . . . .	page 4
Specifications . . . . .	page 6
Product Certifications . . . . .	page 10
Dimensional Drawings. . . . .	page 12

## Success With Smart Wireless

### Self-Organizing Networks

Self-forming, intelligent devices that provide exceptional data reliability and network stability. The Rosemount 702 works the same as wired devices, allowing you to leverage existing practices, training and maintenance procedures, but without the added wiring costs.

### SmartPower™ Technologies

Rosemount devices incorporate SmartPower™ technologies, which refers to the benefits that users enjoy due to the engineering efforts made to reduce power consumption. Emerson has power-optimized our instrumentation, both hardware and software, to extend power module life while still delivering highly reliable measurements with rich HART data and diagnostic information.

### Layered Security Keeps Your Network Safe

Emerson Process Management's layered approach to wireless network security ensures that your network stays protected. The network devices implement industry standard Encryption, Authentication, Verification, Anti-Jamming and Key Management methods to ensure that data transmissions are received only by the Wireless Gateway.

### Integral LCD Display

Local indication of discrete input state and diagnostics provides real time and accurate verification of process conditions.

### Reliable Transmitter Performance

The 702 ensures top transmitter performance in harsh and/or noisy EMI/RFI environments.

### Digital Field Devices that Power PlantWeb



The Rosemount 702 powers PlantWeb® by communicating important discrete input state to ensure process health and enable economical single or dual switch architecture.

### Mounting Flexibility

PlantWeb head mount transmitters to be direct mounted via a switch or remote mounted, allowing the flexibility needed to reach any measurement point. The PlantWeb head also offers an LCD for local display that is easily visible, even in remote installations.

## SMART WIRELESS SOLUTIONS

### Smart Wireless Gateway

The Emerson Smart Wireless Gateway integrates the self-organizing network into the host system, providing industry leading security and data reliability.

### Rosemount 3051S Wireless Series

The scalable 3051S enables fully integrated pressure, flow and level self organizing network solutions to optimize plant performance and reduce risk.

### Smart Wireless THUM™ Adapter

The THUM Adapter allows you to wirelessly transmit HART measurement and diagnostic information from any wired HART device.

### Rosemount 648 Wireless Temperature Transmitter

The Rosemount 648 integrates temperature measurement into a self organizing network, providing best in class security, reliability, SmartPower, and network scalability, optimizing plant performance while minimizing maintenance.

### Rosemount 848T Wireless Temperature Transmitter

The 848T Wireless temperature transmitter integrates four temperature measurements into a self-organizing network. It provides a reliable and cost effective solution for high density applications.

## WirelessHART... The Industry Standard

### Self-Organizing, Adaptive Mesh Routing

- No wireless expertise required, devices automatically find several alternative communication paths
- Network continuously monitors paths for degradation and repairs itself
- Adaptive behavior provides reliable, hands-off operation and simplifies network deployments, expansion and reconfiguration
- Supports both star and mesh topologies

### Industry Standard Radio with Channel Hopping

- Standard IEEE 802.15.4 radios
- 2.4 GHz ISM band sliced into 15 radio-channels
- Continually “hop” across channels to avoid interference and increase reliability
- Direct sequence spread spectrum (DSSS) with channel hopping technology delivers >99% reliability in challenging radio environment

### Self-Healing Network

- The self-organizing, self-healing network manages multiple communication paths for any given device. If an obstruction is introduced into the network, data will continue to flow because the device already has other established paths. The network will then lay in more communication paths as needed for that device.

### Seamless Integration to Existing Hosts

- Transparent and seamless integration
- Same control system applications
- Gateways connect using industry protocols

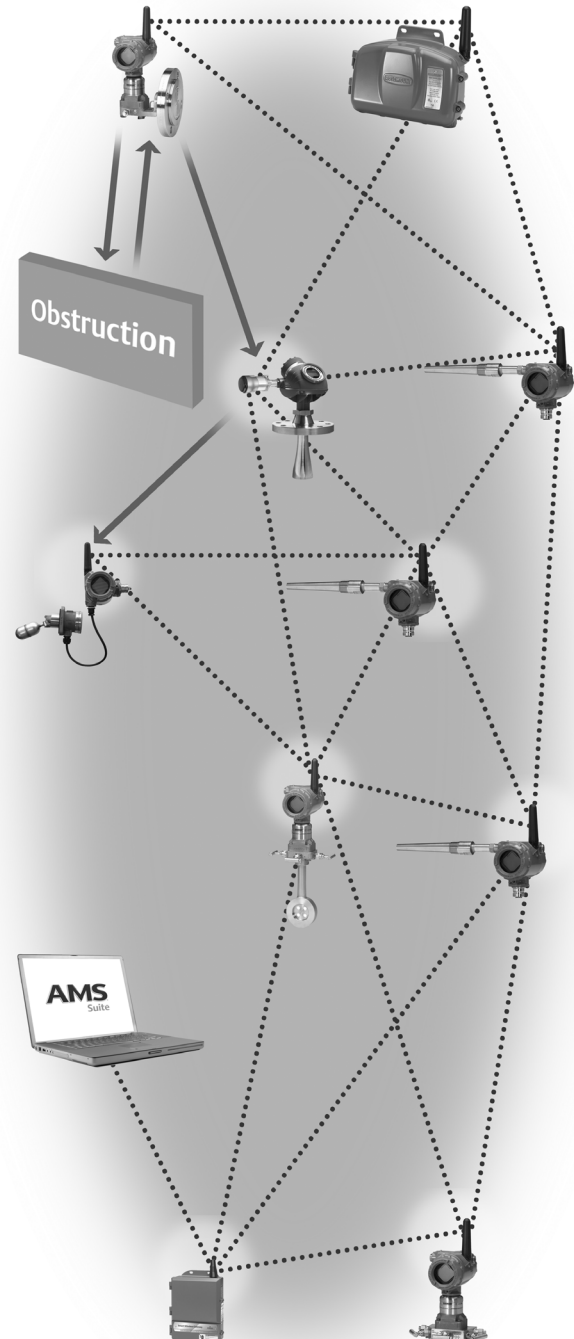

## Ordering Information

Table 1. 702 Wireless Discrete Transmitter Ordering Information

★ The Standard offering represents the most common options. The starred options (★) should be selected for best delivery. The Expanded offering is subject to additional delivery lead time.

Product Description			
<b>Standard</b>			<b>Standard</b>
702	Discrete Transmitter		★
Transmitter Type			
<b>Standard</b>			<b>Standard</b>
D	Wireless Field Mount		★
Output			
<b>Standard</b>			<b>Standard</b>
X	Wireless		★
Measurement			
<b>Standard</b>			<b>Standard</b>
22	Dual Discrete Inputs (Dry Contact)		★
61 <sup>(1)</sup>	Liquid Hydrocarbon Detection (For use with TraceTek Fast Fuel Sensor or TraceTek sensing cable)		★
Housing			
<b>Standard</b>			<b>Standard</b>
D	Dual Compartment Housing - Aluminum		★
E	Dual Compartment Housing - SST		★
Conduit Threads			
<b>Standard</b>			<b>Standard</b>
1	1/2 - 14 NPT		★
Certifications		Measurement Option Codes	
<b>Standard</b>			<b>Standard</b>
I5	FM Intrinsically Safe, Non-Incendive, and Dust Ignition-Proof	22, 61	★
I6	CSA Intrinsically Safe	22, 61	★
I1	ATEX Intrinsic Safety	22, 61	★
I7	IECEx Intrinsic Safety	22, 61	★
I4	TIIS Intrinsic Safety	22	★
I3	China Intrinsic Safety	22	★
NA	No Approval	22, 61	★

### Wireless Options

Wireless Update Rate			
<b>Standard</b>			<b>Standard</b>
WA	User Configurable Update Rate		★
Operating Frequency and Protocol			
<b>Standard</b>			<b>Standard</b>
3	2.4 GHz DSSS, WirelessHART		★
Omnidirectional Wireless Antenna			
<b>Standard</b>			<b>Standard</b>
WK	Long Range, Integral Antenna		★
WM	Extended Range, Integral Antenna		★
SmartPower™			
<b>Standard</b>			<b>Standard</b>
1 <sup>(2)</sup>	Power Module Adapter, Intrinsically Safe (Power Module separate)		★

# Product Data Sheet

00813-0100-4702, Rev DA

April 2010

# Rosemount 702

Table 1. 702 Wireless Discrete Transmitter Ordering Information

★ The Standard offering represents the most common options. The starred options (★) should be selected for best delivery.

The Expanded offering is subject to additional delivery lead time.

## Other Options (Include with selected model number)

Meter		
<b>Standard</b>		<b>Standard</b>
M5 <sup>(1)</sup>	LCD Meter	★
<b>Mounting Bracket</b>		
<b>Standard</b>		<b>Standard</b>
B4	Universal L mounting bracket for 2-inch pipe mounting - SST bracket and bolts	★
<b>Configuration</b>		
<b>Standard</b>		<b>Standard</b>
C1	Factory Configure Date, Descriptor, Message Fields, and Wireless Parameters	★
<b>Cable Gland</b>		
<b>Standard</b>		<b>Standard</b>
G2	Cable gland (7.5 mm - 11.9 mm)	★
G4 <sup>(3)</sup>	Thin Wire Cable Gland (3 mm - 8 mm)	★
<b>Typical Model Number: 702 D X 22 D 1 NA WA3 WK1 M5</b>		

(1) LCD Display not available for option code 61.

(2) Long-life Power Module must be shipped separately, order Part #00753-9220-0001.

(3) Thin wire cable gland is preferred for measurement option 61.

## Specifications

### Functional Specifications

#### Input

Single or dual SPST dry contacts, single SPDT dry contacts or leak detection. To maintain I.S. ratings, contacts must be limited to simple switches or leak detection only.

#### Output

WirelessHART 2.4 GHz DSSS.

#### Radio Frequency Power Output from Antenna

Long Range (WK option) antenna: Maximum of 10 mW (10 dBm) EIRP

Extended Range (WM option) antenna: Maximum of 18 mW (12.5 dBm) EIRP

#### Local Display<sup>(1)</sup>

The optional integral LCD can display discrete state and diagnostic information. Display updates at transmit rate up to once per minute.

<sup>(1)</sup> The option for a local display is not available with option 61, Liquid Hydrocarbon Leak Detection.

#### Humidity Limits

0–100% relative humidity

#### Update Rate

WirelessHART, user selectable 8 sec. to 60 min.

### Physical Specifications

#### Electrical Connections

##### Wireless Power Module

Replaceable, Intrinsically Safe Lithium-Thionyl Chloride power module with PBT polymer enclosure. Ten year life at one minute update rate.<sup>(1)</sup>

<sup>(1)</sup> Reference conditions are 70° F (21° C), and routing data for three additional network devices.

NOTE: Continuous exposure to ambient temperature limits (-40 °F or 185 °F) (-40 °C or 85 °C) may reduce specified power module life by less than 20 percent.

##### Switch Terminals

Screw terminals permanently fixed to terminal block

#### HART Communicator Connections

##### Communication Terminals

Clips permanently fixed to terminal block

### Materials of Construction

#### Enclosure

Housing - Low-copper aluminum, or stainless steel

Paint - Polyurethane

Cover O-ring - Buna-N

#### Terminal Block and Power Module Pack

PBT

#### Antenna

PBT/PC integrated omnidirectional antenna

#### Weight

Low - Copper Aluminum:

702 without LCD - 4.6 lbs. (2.0 kg)

702 with M5 LCD - 4.7 lbs (2.1 kg)

Stainless Steel:

702 without LCD - 8.0 lbs. (3.6 kg)

702 with M5 LCD - 8.1 lbs (3.7 kg)

#### Enclosure Ratings (702)

NEMA 4X, and IP66/67.

#### Mounting

Transmitters may be attached directly to switch, brackets also permit remote mounting. See "Dimensional Drawings" on page 12.

**Performance Specifications**

**ElectroMagnetic Compatibility (EMC)**

**All Models:**

Meets all relevant requirements of EN 61326-2-3:2006

**Vibration Effect**

Output unaffected when tested per the requirements of IEC60770-1 field or pipeline with high vibration level (10-60 Hz 0.21mm displacement peak amplitude / 60-2000 Hz 3g).

Output unaffected when tested per the requirements of IEC60770-1 field with general application or pipeline with low vibration level (10-60 Hz 0.15mm displacement peak amplitude / 60-500 Hz 2g).

**Temperature Limits**

Description	Operating Limit	Storage Limit
Without LCD Display	-40 to 185 °F -40 to 85 °C	-40 to 185 °F -40 to 85 °C
With LCD Display	-4 to 175 °F -20 to 80 °C	-40 to 185 °F -40 to 85 °C

**Dry Contact Inputs, Measurement option code 22**

**Terminal Block Connections**

Figure 1. 702 Sensor Connections

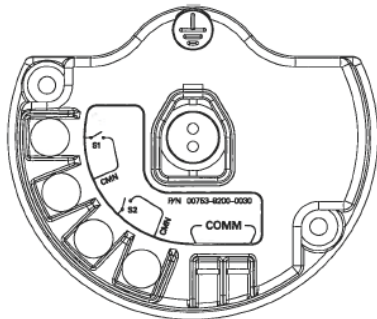

**Wireless Output Specifications**

**Dry Contact Inputs, Measurement option code 22**

**Dual Input, No Logic**

The 702 Discrete Transmitter will accept the input from one or two single pole single throw switches on inputs S1 and S2. The wireless output of the transmitter will be both a primary variable (PV) and a secondary variable (SV). The PV is determined by the S1 input. The SV is determined by the S2 input. A closed switch drives a TRUE output. An Open switch drives a FALSE output.

Figure 2. Single, Dual Input

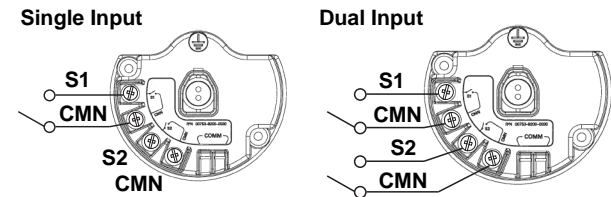

Single or Dual Input, No Logic			
Switch Input	Wireless Output	Switch Input	Wireless Output
S1	PV	S2	SV
Closed	TRUE (1.0)	Closed	TRUE (1.0)
Open	FALSE (0.0)	Open	FALSE (0.0)

If inverted output is selected, any outputs will be inverted, as shown below.

Single or Dual Input, No Logic, Inverted Output			
Switch Input	Wireless Output	Switch Input	Wireless Output
S1	PV	S2	SV
Closed	FALSE (0.0)	Closed	FALSE (0.0)
Open	TRUE (1.0)	Open	TRUE (1.0)

## Dry Contact Inputs (Continued)...

### Dual Input, Limit Contact Logic

When configured for Limit Contact Logic, the 702 Discrete Transmitter will accept the input from two single pole single throw switches on inputs S1 and S2, and will use limit contact logic for the determination of the wireless outputs.

Figure 3. Dual Input, Limit Contacts

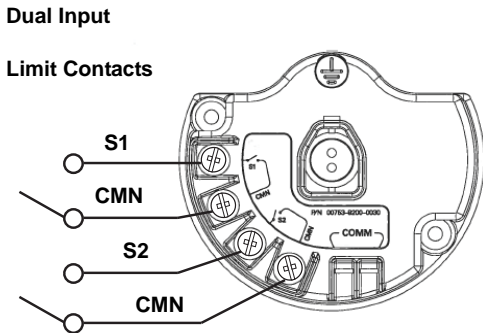

Dual Input, Limit Contact Logic			
Switch Input	Wireless Output	Switch Input	Wireless Output
S1	PV	S2	SV
Open	Open	TRAVEL (0.5)	TRAVEL (0.5)
Open	Closed	FALSE (0.0)	FALSE (0.0)
Closed	Open	TRUE (1.0)	TRUE (1.0)
Closed	Closed	FAULT(NaN)	FAULT(NaN)

If inverted output is selected, any outputs will be inverted, as shown below.

Dual Input, Limit Contact Logic			
Switch Inputs		Wireless Outputs	
S1	PV	S2	SV
Open	Open	FAULT(NaN)	FAULT(NaN)
Open	Closed	TRUE (1.0)	TRUE (1.0)
Closed	Open	FALSE (0.0)	FALSE (0.0)
Closed	Closed	TRAVEL (0.5)	TRAVEL (0.5)

### Dual Input, Opposing Contact Logic

When configured for Opposing Contact Logic, the 702 Discrete Transmitter will accept the input from a double pole single throw switches on inputs S1 and S2, and will use opposing contact logic for the determination of the wireless outputs.

Figure 4. Dual Input, Opposing Contact

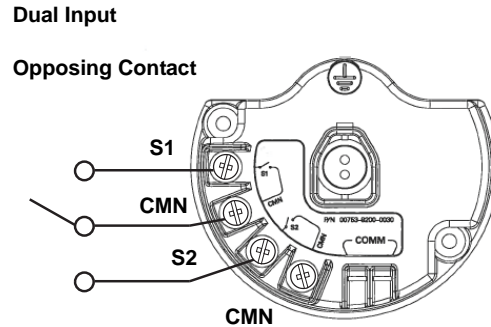

Dual Input, Opposing Contact Logic			
Switch Inputs		Wireless Outputs	
S1	S2	PV	SV
Open	Open	FAULT(NaN)	FAULT(NaN)
Open	Closed	FALSE (0.0)	FALSE (0.0)
Closed	Open	TRUE (1.0)	TRUE (1.0)
Closed	Closed	FAULT(NaN)	FAULT(NaN)

If inverted output is selected, any outputs will be inverted, as shown below.

Dual Input, Opposing Contact Logic, Inverted Output			
Switch Inputs		Wireless Outputs	
S1	S2	PV	SV
Open	Open	FAULT(NaN)	FAULT(NaN)
Open	Closed	TRUE (1.0)	TRUE (1.0)
Closed	Open	FALSE (0.0)	FALSE (0.0)
Closed	Closed	FAULT(NaN)	FAULT(NaN)

**Liquid Hydrocarbon Detection, Measurement option code 61**

**Terminal Block Connections**

Figure 5. Fuel Sensor Terminal Diagram

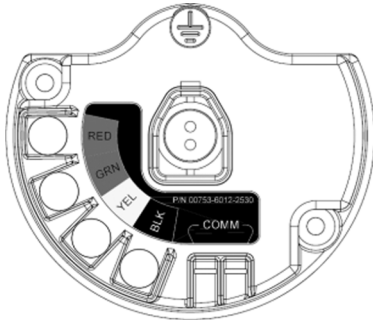

The Liquid Hydrocarbon Detection configuration is intended for use with the Tyco® TraceTek® Fast Fuel Sensor, or TraceTek sensing cable.

Figure 6. Fuel Sensor Connection Diagram

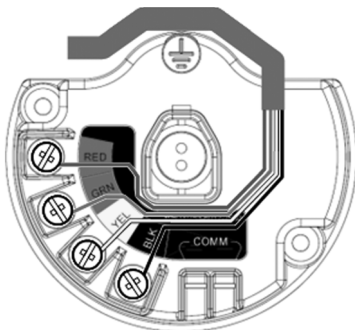

The connections to the Fast Fuel Sensor TraceTek sensing cable are made by matching the appropriately colored wires to the matching colored termination lugs.

- The Emerson Smart Wireless 702 Discrete Transmitter can support up to 3 Fast Fuel sensors. These Fast Fuel sensors are connected using TraceTek Modular Leader Cable (TT-MLC-MC-BLK), optional modular jumper cables (TT-MJC-xx-MC-BLK) and branching connectors (TT-ZBC-MC-BLK) as suggested in Figure 7.

Figure 7. Fuel Sensor wiring



- The Emerson Smart Wireless 702 Discrete Transmitter can support up to 500 feet of TraceTek hydrocarbon or solvent sensor cable (TT5000 or TT5001 series). The total amount of sensor cable connected to a single 702 transmitter is not to exceed 500 ft. However leader cable, jumper cables (if used) and branch connectors are not included in the 500 foot limit. See Figure 8 for typical configurations.

Figure 8. Fuel Sensor sensor cable wiring

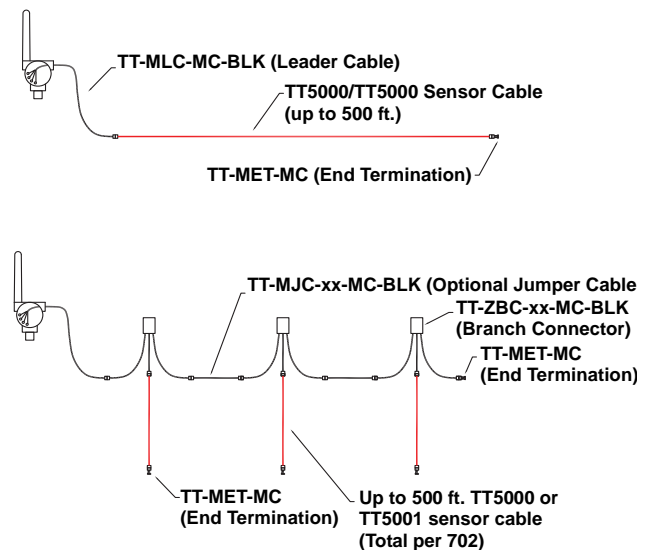

## Product Certifications

### ROSEMOUNT 702

#### Approved Manufacturing Locations

Rosemount Inc. – Chanhassen, Minnesota, USA  
Emerson Process Management GmbH & Co. - Karlstein, Germany  
Emerson Process Management Asia Pacific Private Limited - Singapore

#### European Directive Information

The EC declaration of conformity for all applicable European directives for this product can be found at [www.rosemount.com](http://www.rosemount.com). A hard copy may be obtained by contacting an Emerson Process Management representative.

#### Telecommunication Compliance

All wireless devices require certification to ensure that they adhere to regulations regarding the use of the RF spectrum. Nearly every country requires this type of product certification. Emerson is working with governmental agencies around the world to supply fully compliant products and remove the risk of violating country directives or laws governing wireless device usage.

#### FCC and IC

This device complies with Part 15 of the FCC Rules. Operation is subject to the following conditions: This device may not cause harmful interference. This device must accept any interference received, including interference that may cause undesired operation.

This device must be installed to ensure a minimum antenna separation distance of 20 cm from all persons.

#### Ordinary Location Certification for FM Approvals

As standard, the transmitter has been examined and tested to determine that the design meets basic electrical, mechanical, and fire protection requirements by FM Approvals, a nationally recognized testing laboratory (NRTL) as accredited by the Federal Occupational Safety and Health Administration (OSHA).

#### Hazardous Locations Certificates

##### North American Certifications

###### FM Approvals

- 15 FM Intrinsically Safe, Non-Incendive and Dust Ignition-Proof Intrinsically Safe for Class I/II/III, Division 1, Groups A, B, C, D, E, F, and G.  
Zone Marking: Class I, Zone 0, AEx ia IIC  
Temperature Codes T4 (-50 °C <= T<sub>amb</sub> <= 70 °C), T5 (-50 °C <= T<sub>amb</sub> <= 40 °C)  
Non-incendive for Class I, Division 2, Groups A, B, C, and D.  
Dust Ignition-proof for Class II/III, Division 1, Groups E, F, and G.  
Intrinsically Safe and non-incendive when installed in accordance with Rosemount drawing 00702-1000.  
For use with Rosemount SmartPower<sup>®</sup> Options P/N 753-9220-0001 only.  
Enclosure Type 4X / IP66 / IP67

##### CSA International

- 16 CSA Intrinsically Safe  
Intrinsically Safe for Class I, Division 1, Groups A, B, C, and D.  
Temp Code T3C  
Enclosure Type 4X / IP66 / IP67  
For use with Rosemount SmartPower Options P/N 753-9220-0001 only  
Intrinsically Safe when installed per Rosemount drawing 00702-1020

##### European Certifications

- 11 ATEX Intrinsic Safety  
Certificate No.: BASEEFA07ATEX0239X  II 1G  
Ex ia IIC T4 (-60 °C <= T<sub>amb</sub> <= 70 °C), Ex ia IIC T5 (-60 °C <= T<sub>amb</sub> <= 40 °C)  
CE 1180  
IP66 / IP67  
For use with Rosemount SmartPower™ options P/N 753-9220-XXXX only  
**Special conditions for safe use (X)**  
The surface resistivity of the antenna is greater than 1 gigaohm. To avoid electrostatic charge build-up, it must not be rubbed or cleaned with solvents or a dry cloth.

TABLE 2. Sensor Parameters

Dry Contact Inputs Option Code 22	Liquid Hydrocarbon Detection Option Code 61
U <sub>o</sub> = 6.51 V	U <sub>o</sub> = 7.8 V
I <sub>o</sub> = 26 mA	I <sub>o</sub> = 92 mA
P <sub>o</sub> = 42.6 mW	P <sub>o</sub> = 180 mW
C <sub>o</sub> = 10.9 uF	C <sub>o</sub> = 9.2 uF
L <sub>o</sub> = 25 mH	L <sub>o</sub> = 5 mH

**IECEX System Certifications**

17 IECEX Intrinsic Safety

Certificate No.: IECEXBAS07.0082X

Ex ia IIC T4 (-60 °C ≤ T<sub>amb</sub> ≤ 70 °C), Ex ia IIC T5 (-60 °C ≤ T<sub>amb</sub> ≤ 40 °C)

IP66 / IP67

For use with Rosemount SmartPower options P/N

753-9220-XXXX only

**Special conditions for safe use (X)**

The surface resistivity of the antenna is greater than 1 gigaohm. To avoid electrostatic charge build-up, it must not be rubbed or cleaned with solvents or a dry cloth.

TABLE 3. Sensor Parameters

Dry Contact Inputs Option Code 22	Liquid Hydrocarbon Detection Option Code 61
U <sub>o</sub> = 6.51 V	U <sub>o</sub> = 7.8 V
I <sub>o</sub> = 26 mA	I <sub>o</sub> = 92 mA
P <sub>o</sub> = 42.6 mW	P <sub>o</sub> = 180 mW
C <sub>o</sub> = 10.9 uF	C <sub>o</sub> = 9.2. uF
L <sub>o</sub> = 25 mH	L <sub>o</sub> = 5 mH

**Japanese Certifications**

14 TIIS Intrinsic Safety

Ex ia IIC T4

Certificate Option Code 22	Description
TC18457	Frequency/Protocol Option WA1
TC18640	Frequency/Protocol Option WA3

**China (NEPSI) Certifications**

13 China Intrinsic Safety

Certificate No. (Manufactured in Chanhassen or Singapore):

GYJ081015

Ex ia IIC T4/T5

**Special Condition for Safe Use**

- The temperature class depends on ambient temperature range as follows:

Temperature Class	Ambient Temperature Range
T4	(-60 ~ +70) °C
T5	(-60 ~ +40) °C

- Safety Parameters:

Dry Contact Inputs Option Code 22
U <sub>o</sub> = 6.6 V
I <sub>o</sub> = 26.2 mA
P <sub>o</sub> = 42.6 mW
C <sub>o</sub> = 10.9 uF
L <sub>o</sub> = 25 uH

- The cable entry of transmitter should be protected to ensure the degree of protection of the enclosure IP 20 (GB4208-1993) at least.

- The cables between transmitter and associated apparatus should be shielded cables (the cables must have insulated shield). The cable core section area should be more than 0.5 mm<sup>2</sup>. The shield has to be grounded reliably. The wiring has to not be affected by electromagnetic disturbance.
- COMM interface is forbidden to use in hazardous location.
- Associated apparatus should be installed in a safe location, and during installation, operation, and maintenance, the regulations of the instruction manual have to be strictly observed.
- End users are not permitted to change any components insides.
- During installation, use and maintenance transmitter, observe the following standards.
  - GB3836.13-1997 "Electrical apparatus for explosive gas atmospheres Part 13: Repair and overhaul for apparatus used in explosive gas atmospheres"
  - GB3836.15-2000 "Electrical apparatus for explosive gas atmospheres Part 15: Electrical installations in hazardous area (other than mines)"
  - GB3836.16-2006 "Electrical apparatus for explosive gas atmospheres Part 16: Inspection and maintenance of electrical installation (other than mines)"
  - GB50257-1996 "Code for construction and acceptance of electric device for explosion atmospheres and fire hazard electrical equipment installation engineering"
- Note all installation practices must be followed and if connected to a device that doesn't meet these same approval requirements, the overall system installed approval may be affected.

### Dimensional Drawings

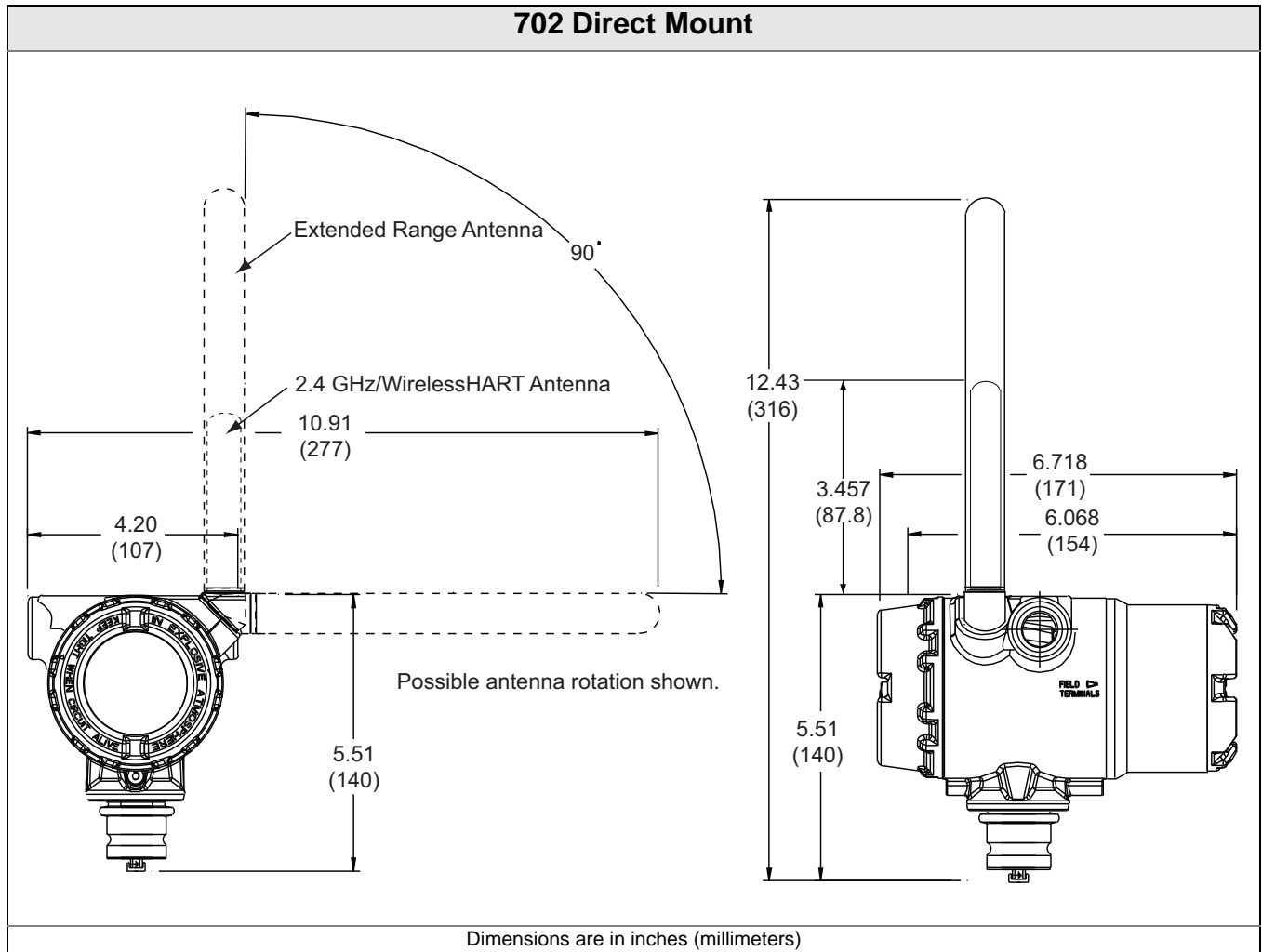



*The Emerson logo is a trade mark and service mark of Emerson Electric Co.  
Rosemount, the Rosemount logotype, SmartPower and THUM are registered trademarks of Rosemount Inc.  
PlantWeb is a registered trademark of one of the Emerson Process Management group of companies.  
Tyco and TraceTek are trademarks of Tyco Thermal Controls LLC or its affiliates.  
All other marks are the property of their respective owners.*

*Standard Terms and Conditions of Sale can be found at [www.rosemount.com/terms\\_of\\_sale](http://www.rosemount.com/terms_of_sale)*

© 2010 Rosemount Inc. All rights reserved.

**Emerson Process Management  
Rosemount Measurement**  
8200 Market Boulevard  
Chanhassen, MN 55317 USA  
T (U.S.) 1-800-999-9307  
T (International) (952) 906-8888  
F (952) 949-7001  
[www.rosemount.com](http://www.rosemount.com)

**Emerson Process Management**  
Blegistrasse 23  
P.O. Box 1046  
CH 6341 Baar  
Switzerland  
T +41 (0) 41 768 6111  
F +41 (0) 41 768 6300

**Emerson FZE**  
P.O. Box 17033  
Jebel Ali Free Zone  
Dubai UAE  
T +971 4 883 5235  
F +971 4 883 5312

**Emerson Process ManagementAsia  
Pacific Pte Ltd**  
1 Pandan Crescent  
Singapore 128461  
T +65 6777 8211  
F +65 6777 0947  
Service Support Hotline: +65 6770 8711  
Email: [Enquiries@AP.EmersonProcess.com](mailto:Enquiries@AP.EmersonProcess.com)



**EMERSON™**  
Process Management