

**QuickNet™ System
Installation Manual**

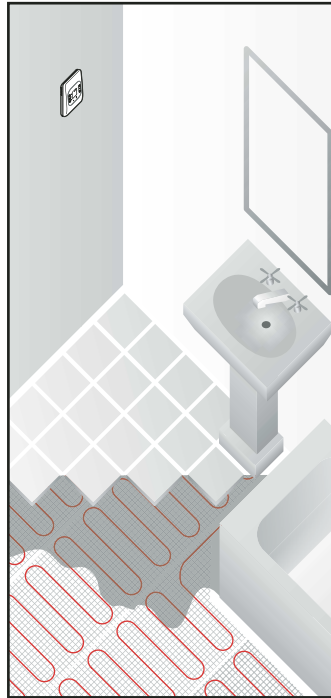

**Floor warming
system**

tyco

Thermal Controls

We manage the heat you need™

Important Safeguards and Warnings



WARNING: Shock and Fire Hazard.

If the QuickNet mat is damaged or not installed properly, fire or shock could occur resulting in serious personal injuries or damage to property. You must carefully follow the warnings and instructions contained in this manual. Contact Tyco Thermal Controls for assistance.

- The QuickStat thermostat must be used. It has a ground-fault circuit interrupter (GFCI) to prevent electric shock.
- The QuickNet system must be installed by qualified personnel familiar with generally accepted construction techniques and safe electrical practices. The installation must comply with all national and local electrical codes. If you are unfamiliar with these requirements, contact a licensed electrician.
- Electric wiring and the heating mat are installed in the floor. Be sure that the floor is not penetrated by nails, screws, or similar devices that can cause damage on first installation or during subsequent floor repairs in the future.
- If the QuickNet system is damaged, it must be replaced. Do not attempt to splice or repair any part of the system.
- The QuickNet heating cable cannot be cut to length, crossed over itself, or installed closer than the spacing in the mat.



IMPORTANT: Installation Guidelines

- QuickNet mats can only be installed beneath ceramic tile or natural stone surfaces. Do not install beneath wooden, carpeted, linoleum, or other type floors.
- Do not step directly on or damage the heating cable during installation.
- Do not install the QuickNet mat across expansion joints.
- Follow the manufacturer's instructions for installing tiles, scratch coat, thin-set mortar, or quick drying mortar beds.
- Locate the splice connection between the heating cable and the power cable in the mortar. Do not install it in conduit. Handle with care and do not bend or pull on the joint.
- Be sure the sub floor is clean, rigid, flat, level and free of cracks.
- Position the temperature sensor immediately under the tile or stone surface and in the middle of the space between the heating cable run.
- Do not allow heating cable, cold lead, or floor temperature sensor to cross over themselves or each other.

Table of Contents

| | | |
|---|----------------------|----|
| 1 | General Information | 1 |
| 2 | QuickNet System | 3 |
| 3 | Floor Warming Design | 6 |
| 4 | Product Selection | 8 |
| 5 | Electrical Rough-In | 10 |
| 6 | Installation | 11 |
| 7 | Commissioning | 18 |
| 8 | Troubleshooting | 20 |
| 9 | Commissioning Record | 22 |

1.1 Use of the Manual

This manual describes the Raychem® QuickNet™ floor warming system—how to design the room, select the product and install the system. It is important to thoroughly review this manual and the following document prior to installation:

- *QuickStat® Thermostat Installation and Operation Manual (H57725)*

For additional information regarding any aspect of the QuickNet system, contact:

Tyco Thermal Controls

300 Constitution Drive
Menlo Park, CA 94025-1164 USA
Tel (800) 545-6258
Fax (800) 596-5004
info@tycothermal.com
www.tycothermal.com

 **Important:** For the Tyco Thermal Controls warranty and agency approvals to apply, the instructions that are included in this manual and product packages must be followed.

1.2 Safety Guidelines

The safety and reliability of any floor warming system depends on proper design, installation, and testing. Incorrect installation or mishandling of the product can cause damage to the heating cable, system components and property, and can create a risk of fire or shock. The guidelines and instructions contained in this guide are important. Follow them carefully to minimize these risks and to ensure that the QuickNet system performs reliably.

Pay special attention to the following:

- Instructions marked  **Important**
- Safety warnings identified as  **WARNING**

1

General Information

1.3 15-year Limited Warranty



The QuickNet system standard limited warranty is 2 years from the date of purchase. You can extend the limited warranty period to fifteen (15) years for the QuickNet mat only, by completing the on-line warranty form within (30) days of purchase. The complete warranty details and the on-line form can be found at www.tycothermal.com.

2

QuickNet System

2.1 QuickNet System Description

The QuickNet floor warming system is designed for comfort heating of ceramic tile or natural stone floors. The preassembled mats can be installed over wood, with or without a backer-board; or on concrete. The mat is then embedded in mortar and covered with tile or stone.

QuickNet cannot be installed beneath wooden, carpeted, linoleum or other type floors.

The QuickNet system includes the following components:

- QuickNet floor warming mat (with 10-foot cold lead)
- QuickStat thermostat
- Floor temperature sensor (10-foot length)

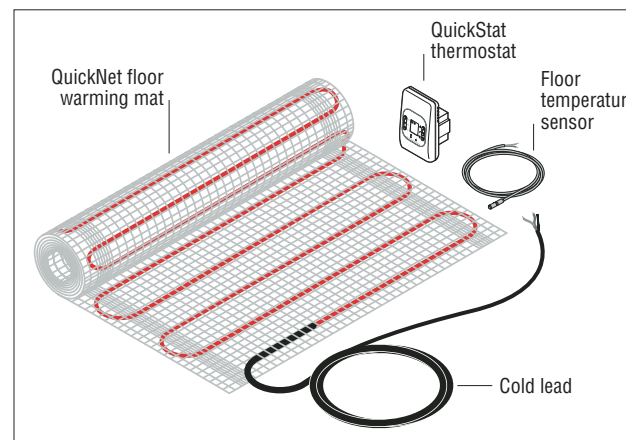

Figure 1: QuickNet system components

The **QuickNet floor warming mat** has a blue heating cable woven into an adhesive-backed red fiberglass mesh. These are manufactured for 120 V and 240 V, and in various lengths of 20-inch widths. The **cold lead** is a black non-heating cord that runs in the wall and connects the system to the thermostat. The **QuickStat thermostat** has an adaptive function that switches the system on to ensure a comfortable floor temperature when you want it. The thermostat comes with a **floor temperature sensor** that is installed under the floor covering and connected to the thermostat to detect the temperature of the floor.

2

QuickNet System

2.2 System Specifications

System Approvals



Mat

| | |
|----------------------------------|--|
| Operating voltage | 120 V and 240 V |
| Power output | 12 W/ft ² (130 W/m ²) ±10% |
| Minimum bending radius | 1.25 in (30 mm) |
| Minimum cable spacing | 3 in (80 mm) |
| Maximum ambient temperature | (85°F) 30°C |
| Minimum installation temperature | 40°F (5°C) |
| Heating cable | 2 wire, grounded, fluoropolymer insulating jackets |
| Cold lead | 2-wire 16 AWG plus ground braid; 10 ft (3 m) length |

Thermostat

| | |
|---------------------------|--|
| Function | On/Off control digital display, 7-day programmable; Class A, 5mA GFCI |
| Supply Voltage | 120/240 V ±15%, 50/60 Hz |
| Maximum switching current | 16 Amp |
| Temperature control range | 40 to 104°F (5 to 40°C) |
| Ambient range | 32 to 104 °F (0 to 40°C) |
| Floor temperature sensor | 2-wire, 10-foot lead wire |

2.3 Product Use

QuickNet floor warming mats can be used on typical interior floor constructions with tile or natural stone surfaces. The typical construction is as follows:

2

QuickNet System

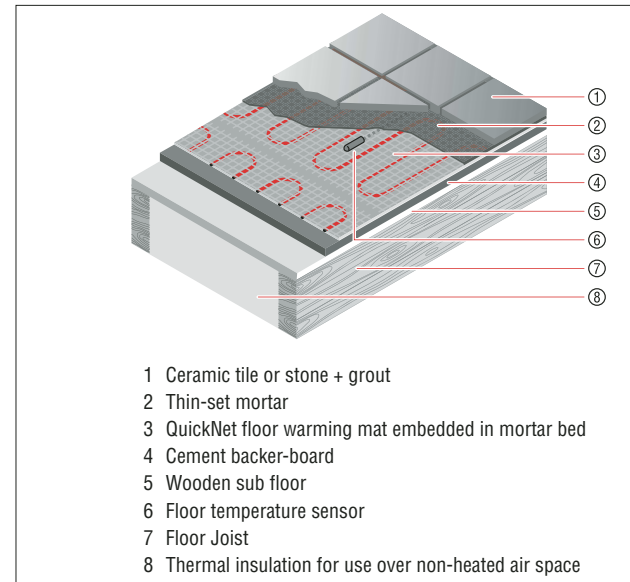

Figure 2: Typical wooden sub floor

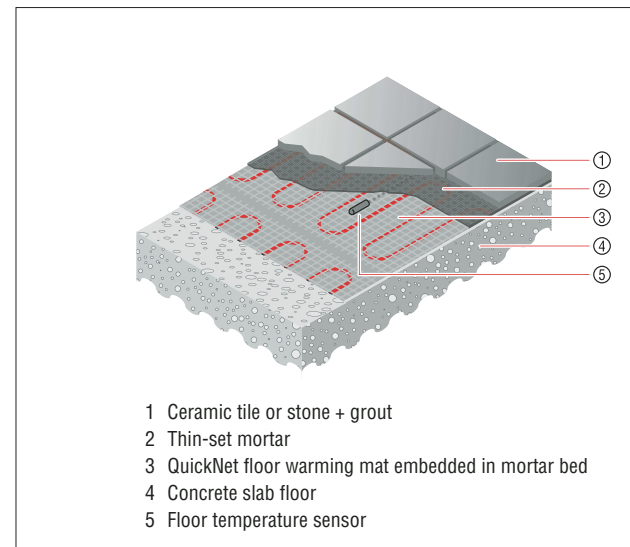

Figure 3: Typical concrete slab

3

Floor Warming Design

3.1 Design the Installation

Step 1: Measure the heated area

Determine the *heated area* of the floor to be warmed. The *heated area* is the area of the floor where there are no permanent fixtures or furniture such as showers, toilets, vanities, or cabinets. Measure the heated area of the floor.

For example, in Figure 4, the area of the bathroom is 96 ft². When you subtract the area of the vanity, shower and toilet, the total heated area is only 74 ft².

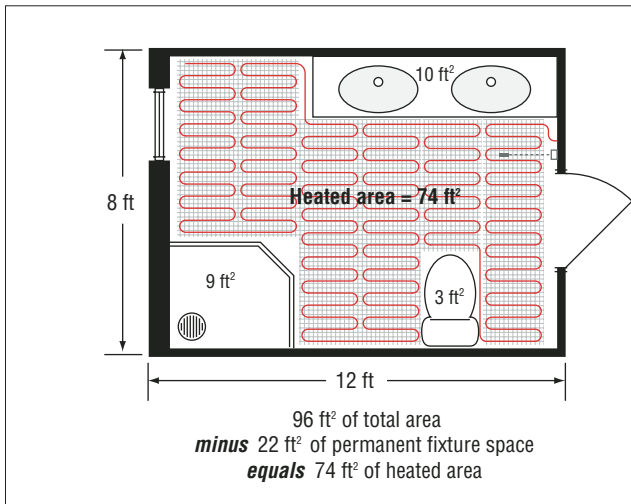

Figure 4: Heated area example

Step 2: Determine the power supply voltage

The available supply voltages include 120 V or 240 V.

3

Floor Warming Design

Step 3: Plan the design

Determine the optimum floor warming mat layout for your heated area to ensure coverage. Select a spot for the thermostat in the wall above the heated area where it can be reached by the 10-foot cold lead on the QuickNet mat, and the 10-foot floor temperature sensor.

Note: If the area of the floor is larger than the QuickNet mat you chose, lay out the mat in the areas you most want heated. The areas without a mat will not be heated and will not be warm.

Note: The predetermined QuickNet spacing must be maintained to ensure proper floor warming. Do not change the mat's uniform heating cable spacing when you lay out the mat or the floor may have cold spots.

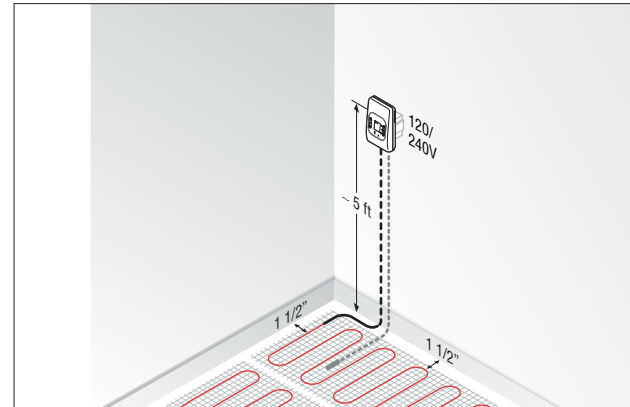

Figure 5: Typical cold lead and floor temperature sensor example

4

Product Selection

4.1 Confirm Your Product Selection

Confirm that your QuickNet mat is no larger than the heated area. Following the example from Figure 4 on page 6, if the heated area is 74 ft², select the 70 ft² mat.

For heated areas greater than 100 ft², select a 240 V QuickNet product and an Extension Kit. Up to 200 ft² of 240 V product may be used with one QuickStat thermostat. Multiple systems may be used for areas larger than 200 ft².

Table 1: Product Selection

| Catalog Number | Heated Area ft ² (m ²) | Mat Dimensions | Output Watts | Current Amps | Resistance Ohms |
|--|---|-----------------|--------------|--------------|-----------------|
| 120 V QuickNet with thermostat | | | | | |
| QUICKNET-010-1 | 10 (0.9) | 20 in x 6.2 ft | 120 | 1 | 120 |
| QUICKNET-020-1 | 20 (1.9) | 20 in x 12.1 ft | 240 | 2 | 60 |
| QUICKNET-030-1 | 30 (2.8) | 20 in x 18.4 ft | 360 | 3 | 40 |
| QUICKNET-040-1 | 40 (3.7) | 20 in x 24.3 ft | 480 | 4 | 30 |
| QUICKNET-050-1 | 50 (4.6) | 20 in x 30.5 ft | 600 | 5 | 24 |
| QUICKNET-060-1 | 60 (5.6) | 20 in x 36.4 ft | 720 | 6 | 20 |
| QUICKNET-070-1 | 70 (6.5) | 20 in x 42.7 ft | 840 | 7 | 17 |
| QUICKNET-080-1 | 80 (7.4) | 20 in x 48.9 ft | 960 | 8 | 15 |
| QUICKNET-090-1 | 90 (8.4) | 20 in x 55.0 ft | 1080 | 9 | 13 |
| QUICKNET-100-1 | 100 (9.3) | 20 in x 61.0 ft | 1200 | 10 | 12 |
| 240 V QuickNet with thermostat | | | | | |
| QUICKNET-050-2 | 50 (4.6) | 20 in x 30.5 ft | 600 | 2.5 | 96 |
| QUICKNET-060-2 | 60 (5.6) | 20 in x 36.4 ft | 720 | 3 | 80 |
| QUICKNET-080-2 | 80 (7.4) | 20 in x 48.9 ft | 960 | 4 | 60 |
| QUICKNET-100-2 | 100 (9.3) | 20 in x 61.0 ft | 1200 | 5 | 48 |
| 240 V Extension Kit without thermostat (add on to 240 V QuickNet to accommodate floors over 100 ft²) | | | | | |
| QUICKNET-050X-2 | 50 (4.6) | 20 in x 30.5 ft | 600 | 2.5 | 96 |
| QUICKNET-060X-2 | 60 (5.6) | 20 in x 36.4 ft | 720 | 3 | 80 |
| QUICKNET-080X-2 | 80 (7.4) | 20 in x 48.9 ft | 960 | 4 | 60 |
| QUICKNET-100X-2 | 100 (9.3) | 20 in x 61.0 ft | 1200 | 5 | 48 |

5

Electrical Rough-In

5.1 Electrical Rough-In

⚠ WARNING: The electrical rough-in must be done by qualified personnel familiar with generally accepted construction techniques and safe electrical practices. The installation must comply with all national and local electrical codes. If you are unfamiliar with these requirements, contact a licensed electrician.

Step 1: Confirm power supply is appropriate

Confirm that the power supply is either 120 or 240 V depending on the mat you chose. The floor warming system must be connected to an appropriate sized electrical circuit. Refer to the Product Selection Table on pages 8–9 for individual mat current levels.

Ground fault protection is provided by the QuickStat thermostat; therefore you can use a conventional circuit breaker.

Step 2: Install electrical junction box

Install the electrical junction box for the thermostat at a convenient height—typically 5 feet above the floor and within reach of the cold lead and the floor temperature sensor.

6

Installation

6.1 Install the QuickNet System

Tools and materials required

You will require the following items to install and test the floor warming system:

- Scissors
- Utility knife
- Wire strippers
- Tape measure
- Screwdriver
- Multimeter

You will also need the appropriate tools and materials to install your particular floor. These will likely include products like self-leveling mortar, thin-set mortar, backer board, tile, a notched trowel, and any other tools for your specific floor.

Follow these steps to ensure a successful QuickNet installation.

Step 1: Prepare the sub floor

Make sure the floor area to be heated is clean, flat, and free of debris that can damage the mat, such as nails, staples or protruding objects.

Drill or cut a hole through the wall sill plate under the electrical junction box location. You will use this hole to route the cold lead and the floor temperature sensor wire to the electrical junction box.

6 Installation

Step 2: Orient the QuickNet floor warming mat

Lay out the mat according to your design, using as few turns as possible and ensuring that the cold lead is near the electrical junction box. Remove the clear plastic lining and roll out the mat with the adhesive side down to temporarily hold it in place. See Figure 4. If it is necessary to change direction, see step 3.

Note: When installing a 240 V QuickNet mat with an Extension mat to accommodate a floor over 100 ft², align the mats so that the red mesh is edge to edge, the heating cable spacing is no less than 3 inches, and both cold leads can reach the electrical junction box. See Figure 6.

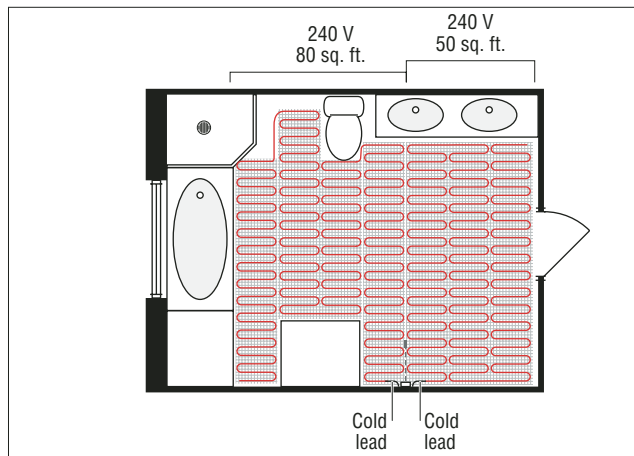

Figure 6: Laying out floor over 100 ft²

If it is necessary to remove the heating cable from the mesh to route around an obstacle, be sure to maintain at least 3 inches of separation between the heating cables.

6 Installation

Step 3: Change the direction of the mat to fit floor design

To make a turn in the direction the mat is being installed, cut the mesh with scissors being careful not to damage the heating cable.

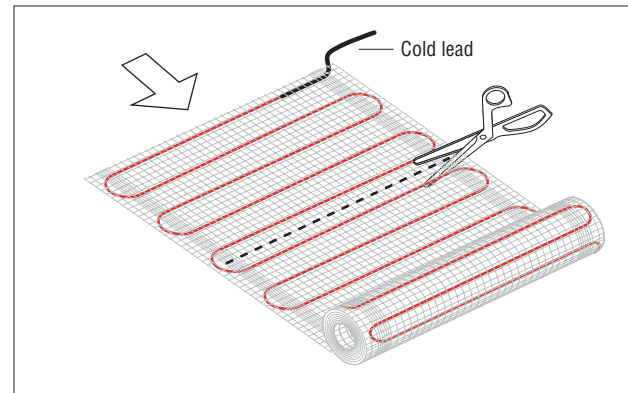

Figure 7: Cutting the mesh

Then align the mat in the desired direction ensuring that the adhesive side of the mat is down and continue to roll it into position.

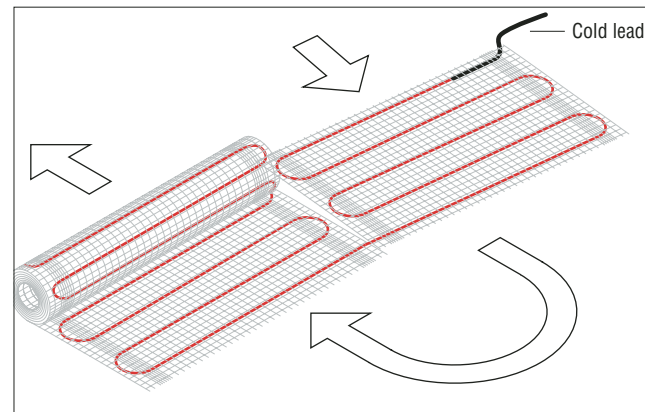

Figure 8: Changing direction

6 Installation

Step 4: Route the cold lead

Position the cold lead of the mat as close as possible to the wall near the electrical junction box. The cold lead must be routed outside of the heating mat, never under or over the heating cable and must not protrude higher than the heating mat.

If the splice is higher than the mat, you must gouge out the sub floor to allow the splice to lay flat under the tile.

Run the cold lead inside the wall to the electrical junction box location.

Important: Position the cord label on the cold lead inside the electrical junction box. If it is necessary to shorten the cold lead, be sure to store the cord label in the junction box.

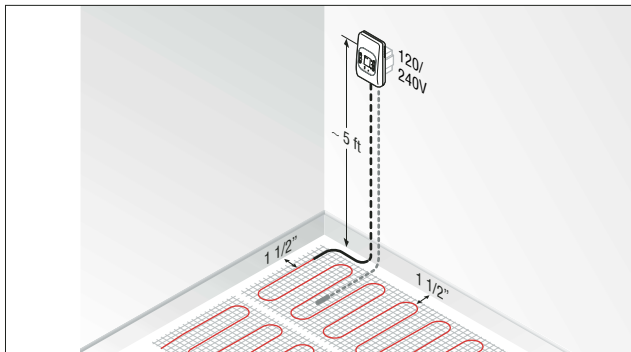

Figure 9: Routing the cold lead

Step 5: Place the floor temperature sensor

Center the floor temperature sensor between two runs of the heating cable, 4 inches from the end of the heating cable loop (see Figure 10). Run the floor temperature sensor inside the wall to the electrical junction box location.

6 Installation

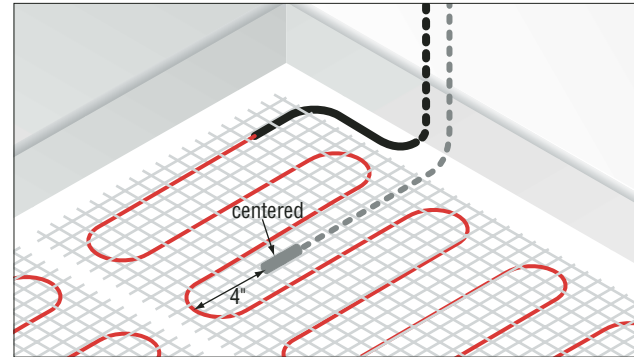

Figure 10: Placing the floor temperature sensor

Important: Do not allow heating cable, cold lead, or floor temperature sensor to cross over themselves or each other.

Note: When installing a 240 V QuickNet mat with an Extension mat to accommodate a floor over 100 ft², use only one floor temperature sensor and one thermostat to control both mats.

Step 6: Perform Insulation Resistance Test, Heating Cable Resistance Test, and the Sensor Resistance Test (Before embedding in mortar)

Important: You must perform the insulation resistance test, heating cable resistance test, and the sensor resistance test before you embed the mat in mortar to confirm that the heating cable and floor sensor have not been damaged. For information on how to perform these tests, see Section 7, Commissioning. Record the results in the Commissioning Record in Section 9.

6

Installation

Step 7: Embed the floor warming mat in mortar

After laying out the floor warming mat and routing the cold lead and the floor temperature sensor to the electrical junction box, apply a thin coat of self-leveling mortar over the mat. Be sure to use the flat side of the trowel to avoid any damage to the mat. Spread the mortar evenly over the mat filling in all voids between the floor, mesh and heating cable. Once the surface is smooth and even, allow it to cure to a hard surface before installing the tile or stone.

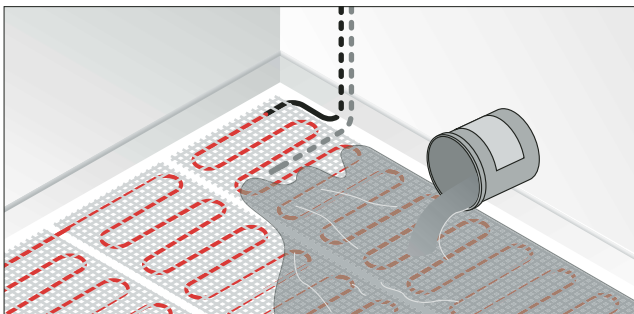

Figure 11: Applying self-leveling mortar

Step 8: Repeat the Insulation Resistance Test, Heating Cable Resistance Test, and the Sensor Resistance Test (After embedding in mortar)

Important: You must repeat the the insulation resistance test, heating cable resistance test, and the sensor resistance test to ensure that the heating cable and floor sensor have not been damaged. For information on how to perform these tests, see Section 7, Commissioning. Record the results in the Commissioning Record in Section 9.

Step 9: Install the tile/stone

To install the tile or stone, apply a layer of acrylic or latex modified thin-set using the ridged side of your trowel. Tile and grout the floor using best industry practices and in accordance with instructions provided by the manufacturer of the tile or stone.

Do not power the QuickNet heating mat until the thin-set and grout are fully cured.

6

Installation

Step 10: Repeat the Insulation Resistance Test, Heating Cable Resistance Test, and the Sensor Resistance Test (After floor covering)

Important: You must repeat the insulation resistance test, heating cable resistance test, and the sensor resistance test to ensure that the heating cable and floor sensor have not been damaged. For information on how to perform these tests, see Section 7, Commissioning. Record the results in the Commissioning Record in Section 9.

Step 11: Install the QuickStat thermostat

Refer to the document *QuickStat Thermostat Installation and Operation Manual (H57725)*, included in the thermostat box for instructions on how to install the thermostat.

Step 12: Program the QuickStat thermostat

Refer to the document *QuickStat Thermostat Installation and Operation Manual (H57725)* included in the thermostat box for instructions on how to program the thermostat.

7 Commissioning

7.1 Commissioning Tests

Important: For the extended 15-year limited warranty to apply, you must perform these tests, record the results on the Commissioning Record, and retain a copy of the record.

You must perform the Insulation Resistance Test, the Heating Cable Resistance Test, and the Sensor Resistance Test three times during the installation process:

1. Before you embed the QuickNet mat in mortar.
2. After you embed the QuickNet mat in mortar but before you install the tile or stone.
3. After the tile or stone has been set.

Insulation Resistance Test

This test ensures that the insulating jackets of the mat are not damaged. A low value indicates the mat has been damaged and must be replaced.

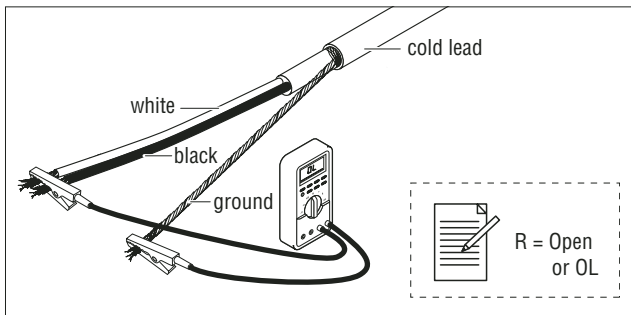

Figure 12: Insulation Resistance test

1. Connect the ground wire to the black lead and both power wires to the red lead of the multimeter.
2. Make sure the meter reads 'Open' or 'OL'. If you get a different reading, contact Tyco Thermal Controls at 800-545-6258.
3. Record these readings on the Commissioning Record.

Heating Cable Resistance Test

This test measures the resistance of the mat and is used to determine circuit integrity.

7 Commissioning

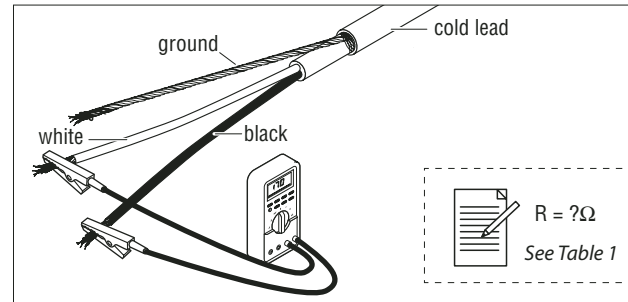

Figure 13: Heating Cable Resistance test

1. Set your multimeter to the 200 ohm range.
2. Connect the multimeter leads to the black and white cold lead wires.
3. Compare this resistance reading to the resistance specified in the Product Selection Table, on pages 8–9. The value should be within $\pm 10\%$. If you get a different reading, contact Tyco Thermal Controls at 800-545-6258.
4. Record these readings on the Commissioning Record.

Sensor Resistance Test

This test measures the resistance of the floor sensor and is used to verify the sensor integrity.

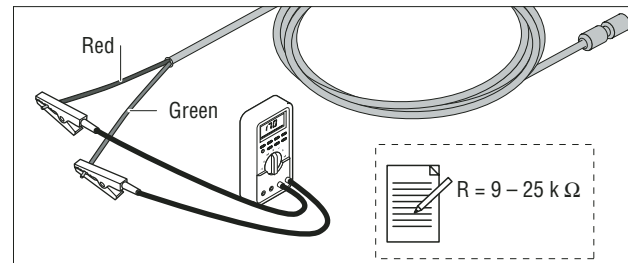

Figure 14: Sensor Resistance test

1. Set your multimeter to the 200 K ohm range.
2. Connect the multimeter leads to the red and green lead wires.
3. Make sure the meter reads between 9 – 25 K Ω . If you get a different reading, contact Tyco Thermal Controls at 800-545-6258.
4. Record these readings on the Commissioning Record.

8

Troubleshooting

| Symptom | Probable Causes | Corrective Action |
|---|---|---|
| Floor doesn't heat | No voltage. | Check circuit breaker. |
| | Circuit breaker tripped. | Ensure that there are not too many mats or other appliances connected on the same circuit. The QuickNet mat may require a dedicated circuit. See the Product Selection table in Section 4 of this manual. |
| | Ground-fault tripped in the thermostat. | Refer to <i>QuickStat Thermostat Installation and Operation Manual</i> , page 3. |
| | Thermostat not turned on. | Refer to Section 6 of this manual, and the <i>QuickStat Thermostat Installation and Operation Manual</i> , pages 2-4. |
| | Mat not connected to QuickStat thermostat. | Refer to <i>QuickStat Thermostat Installation and Operation Manual</i> , pages 2-4. |
| | Floor temperature sensor not connected. | Refer to <i>QuickStat Thermostat Installation and Operation Manual</i> , page 2. |
| Floor warm all the time | Faulty sensor. | Contact Tyco Thermal Controls at 800-545-6258. |
| | Clock not set correctly. | Refer to <i>QuickStat Thermostat Installation and Operation Manual</i> , pages 3-4. |
| Floor not warm enough | QuickStat thermostat setting not set correctly. | Refer to <i>QuickStat Thermostat Installation and Operation Manual</i> , pages 3-5. |
| Installation Instructions not available | | Download the latest version of <i>QuickNet Installation Instructions</i> from www.raychemquicknet.com . |

9

Commissioning Record

QuickNet Commissioning Record (retain this record)

Installer

| | |
|-----------------------|----------------|
| Date of commissioning | Company |
| Name of Installer | |
| Street | |
| City | Postal Code |
| Phone (office) | Phone (mobile) |
| Fax | Email |
| Website | |

Project Data

| | |
|--|--|
| Customer Name | |
| Address | |
| Sub floor type (Circle one) Wood Concrete | Floor covering (Circle one) Ceramic tile Natural stone |
| Room type (Circle one) Kitchen Bathroom Entryway Other | Rated voltage (Circle one) 120 V 240 V |

| | Number | Mat 1 | Mat 2 |
|---------------------------------|---|-------|-------|
| QuickNet Mat | Catalog Number | | |
| | Batch Date (from box or cord label) | | |
| Insulation Resistance | Before embedding in mortar (see pages 15 & 18, Figure 12) | | |
| | After embedding in mortar (see pages 16 & 18, Figure 12) | | |
| | After floor covering (see pages 17 & 18, Figure 12) | | |
| Heating Cable Resistance | Before embedding in mortar (see pages 15 & 19, Figure 13) | | |
| | After embedding in mortar (see pages 16 & 19, Figure 13) | | |
| | After floor covering (see pages 17 & 19, Figure 13) | | |
| Sensor Resistance | Before embedding in mortar (see pages 15 & 19, Figure 14) | | |
| | After embedding in mortar (see pages 16 & 19, Figure 14) | | |
| | After floor covering (see pages 17 & 19, Figure 14) | | |

Installer: please leave this record with homeowner.

Homeowner: you must keep a copy of the completed Commissioning Record in order for the 15-year limited warranty extension to apply.



Thermal Controls

We manage the heat you need™

Tyco, Raychem, QuickNet, QuickStat and We manage the heat you need, are trademarks trademarks of Tyco Thermal Controls LLC or its affiliates.

Important: *All information, including illustrations, is believed to be reliable. Users, however, should independently evaluate the suitability of each product for their particular application. Tyco Thermal Controls makes no warranties as to the accuracy or completeness of the information, and disclaims any liability regarding its use. Tyco Thermal Controls' only obligations are those in the Tyco Thermal Controls Standard Terms and Conditions of Sale for this product, and in no case will Tyco Thermal Controls or its distributors be liable for any incidental, indirect, or consequential damages arising from the sale, resale, use, or misuse of the product. Specifications are subject to change without notice. In addition, Tyco Thermal Controls reserves the right to make changes—without notification to Buyer—to processing or materials that do not affect compliance with any applicable specification.*

Worldwide Headquarters
Tyco Thermal Controls
300 Constitution Drive
Menlo Park, CA 94025-1164
USA
Tel (800) 545-6258
Fax (800) 596-5004
info@tycothermal.com
www.tycothermal.com

Canada
Tyco Thermal Controls
250 West St.
Trenton, Ontario
Canada K8V 5S2
Tel (800) 545-6258
Fax (800) 596-5004

© 2005 Tyco Thermal Controls LLC Printed in USA H67704 08/05