



Energy Efficient Gutter Ice Melting

Model GIT-4 Automatic Gutter Ice Melting Control



Description

Snow and ice on a roof cause a variety of expensive problems including gutter and down spout breakage and interior water damage. In addition, falling ice can endanger pedestrians. Using heating cables for ice melting can eliminate these problems. However, uncontrolled heating is expensive and not energy efficient.

The computerized patented and patent pending GIT-4 Automatic Gutter Ice Melting Control operates ice melting heaters only while required thus insuring energy efficiency and low operating costs. A GIT-4 consists of a gutter-mounted computerized sensor and a control enclosure connected by a 12' 6" (3.8 meter) cable. If the distance between the sensor and control needs to be changed, please contact Customer Service. A GIT-4 includes an RCU-2 Remote Control Unit. It can be located up to 150 feet (45.7 meters) from the control enclosure. It mounts in a single-gang switch box.

The GIT-4 senses both moisture and temperature conditions in the gutter or down spout thus assuring optimum control. Ice melting heaters operate at temperatures below 38° F (3.3° C) while moisture is present. Operation continues a period of time thereafter to insure complete melting. While operating, the heaters are maintained at a nominal temperature of 38° F (3.3° C).

The RCU-2 provides remote monitoring of the ice melting system operation. It also controls GFEP operation and can override automatic heater operation.

Line voltage and ice melting heater connections are located in the control enclosure. The GIT-4 operates from single-phase 120, 208/240 or 277 volt supply selected by a internal jumper connection that is set during installation. It controls single-phase ice melting heater loads of up to 26 amps. The GIT-4 meets the new NEC Class 2 low voltage requirement for wet locations. It is both UL and CUL Listed while the RCU-2 is a NEC Class 2 device. Safety testing was done to UL Standard 873.

Benefits

- Automatic gutter ice melting control
- Energy efficient

Features

- Minimum operating costs
- Maintains ice melting heater efficiency
- Built-in ground fault equipment protection (GFEP) for safety
- UL and CUL Listed to Standard 873
- Remote monitor and control included
- Low cost
- Simple installation

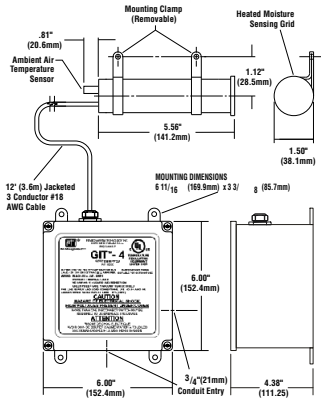

ENVIRONMENTAL TECHNOLOGY, INC.

1302 High Street
South Bend, IN 46601 USA

continued...

Typical Installation

Simplified drawings of installations using both constant wattage and self-limiting heating cables follow. These show typical heating cable placement along with GIT-4's sensor and control enclosure locations. Refer to installation data

provided by the heating cable manufacturer and the GIT-4's instruction manual for more detailed information.

Installations must meet the requirements of both the local and national electrical codes.

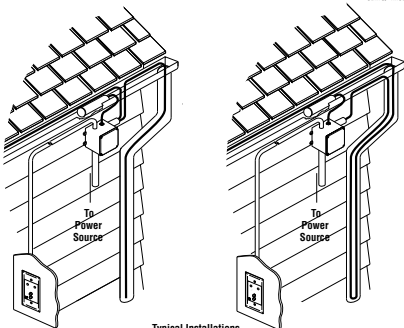

Typical Installations

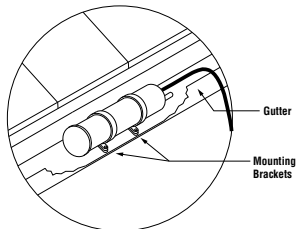

Sensor Orientation

Ordering Information

Order Number	Description
19556	GIT-4 Gutter Ice Melting Control (including instruction manual)
19592	GIT-4 Instruction Manual (extra copy available at no charge)

Limited Warranty

ETI's two year limited warranty covering defects in workmanship and materials applies to this product. Contact Customer Service for complete warranty information.

Disclaimer

Environmental Technology, Inc. makes no representations or warranties, either expresses or implied, with to the contents of this publication or the products that it describes, and specifically disclaims any implied warranties of merchantability or fitness for any particular purpose. Environmental Technology, Inc. reserves the right to revise this publication, and to make changes and improvements to the products described in this publication, without the obligation of Environmental Technology, Inc. to notify any person or organization of such revisions, changes or improvements.



ENVIRONMENTAL TECHNOLOGY, INC.

1302 High Street • South Bend, IN 46601 USA
219-233-1202 • Fax 219-233-2152
Toll Free 800-234-4239 • Toll Free Fax 888-234-4238
www.networketi.com • e-mail: helpdesk@networketi.com